

ANDERSEN

QUARTZ

Installer Manual



www.andersen-ev.com

Revision 1.0

ANDERSEN DISCLAIMER

The Andersen Quartz should only be installed by an electrician with the appropriate knowledge and qualifications. The installation must comply with the current editions of the **IET Code of Practice for Electric Vehicle Charging Equipment installation** and **IET BS 7671 Requirements for Electrical Installations**. Failure to do so could result in injury or death.

It is the responsibility of the installer and/or designer to determine the correct cabling and protective devices where external influences could have an effect on inbuilt protection.

It is also the responsibility of the installer to apply to or notify the relevant Distribution Network Operator (DNO) with the installation details of the charge point and property in accordance with Energy Networks Association (ENA) guidance.

Opening of containment should only be carried out when the supply is isolated from the mains. The undertaking of any live testing should only be carried out by a person or persons qualified to do so.

The installation instructions should be followed closely to ensure correct installation and commissioning. Failure to follow these instructions could result in damage to the Andersen Charge point, existing installation or supplier's equipment.

During and on completion of the installation, it shall be inspected, tested and certified to verify that it complies with the current electrical regulations and standards as applicable.

Before the Andersen Quartz is put into service, we, as the manufacturer, require the installer to simulate a charge with a recognised EVSE adaptor and multifunction tester to prove operation and functionality. Use of this equipment should only be undertaken by someone who has an understanding of its functions and has the experience and knowledge to do so.

ANDERSEN Quartz

Tools Required

2mm terminal screwdriver

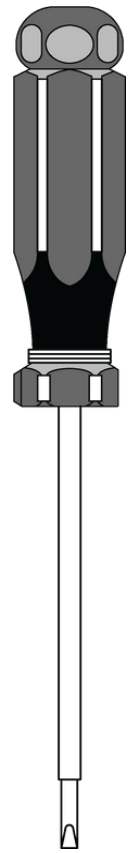

1.5mm HEX key

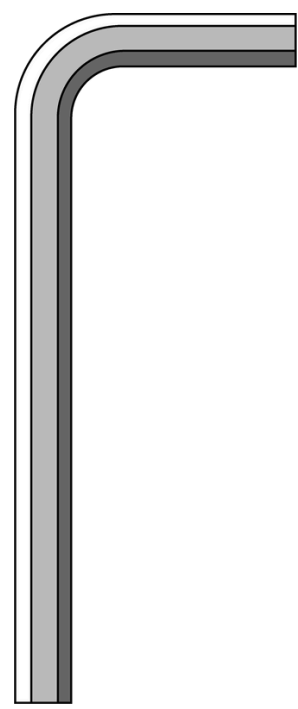

T-25 Anti-Tamper security Bit

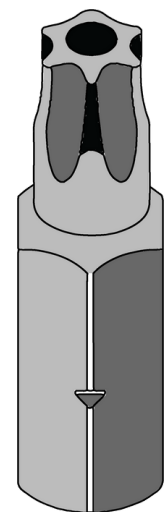

Included

1x 25mm Compression Gland for cable entry

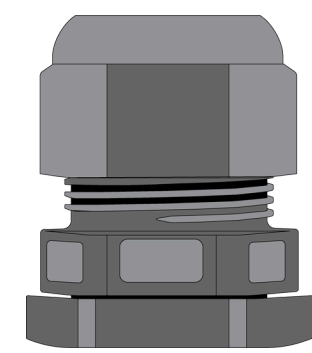

25mm Step Grommet

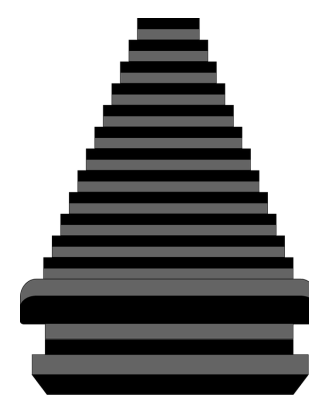

4x rubber sealing washers

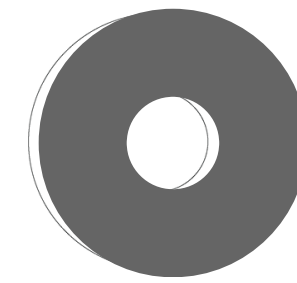

3x Grid CT Clamps if 22kW charger

Grid CT Clamp

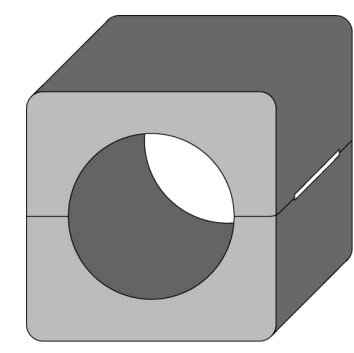

4x 60mm mounting screws

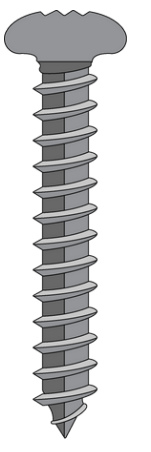

Pre-installed

BOOST BUTTON OPERATION



Boost charge (One button press)



Reset Error (Two button presses)



Enter Network setup mode (Three button presses)



Factory reset (Five button presses)



Boost button located on the bottom, below the status light

OPERATION LED STATUS LIGHT

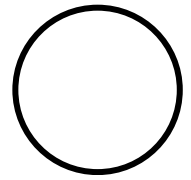

Solid white LED - charge point is in standby mode

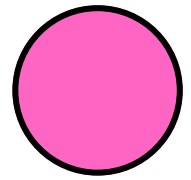

Solid magenta LED - waiting for scheduled charge to start

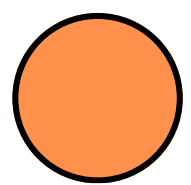

Solid orange LED - waiting for sufficient solar to start charge

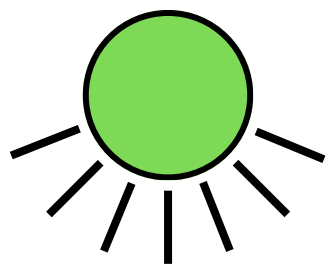

Pulsating green LED - vehicle is charging

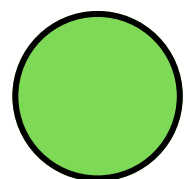

Solid green LED - vehicle has finished charging

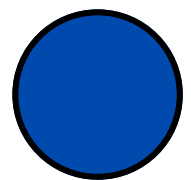

Solid blue LED - charge point is locked by user

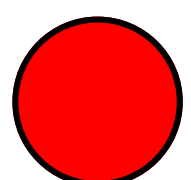

Solid red LED - charge point has detected an error

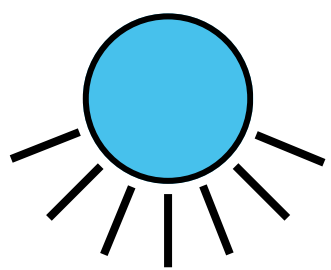

Flashing cyan LED - charge point is in setup mode

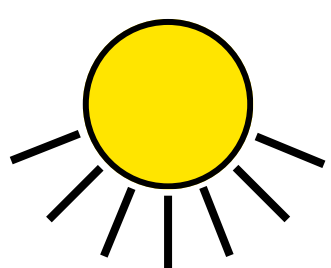

Pulsating yellow LED - charge point is rebooting

All colours in a pulsating sequence - Firmware update in progress

Unpacking and Preparation

Package Contents:

- **Andersen Quartz Unit**
- **Fitting Kit**
- **Welcome Pack**
- **Drill template**
- **Grid CT Clamp (x3 if 3-phase)**
- **Solar CT Clamp (if purchased) - N/A for 22kW unit**
- **Cable hook (if purchased)**

Preparation - First Steps:

- **Carefully remove charge point from box**
- **Check charge point for any damage**
- **Remove middle trim**
- **Remove remainder of housing**
- **Prepare to start installation**

Any damage identified once
unpacked must be reported to
Andersen immediately

Please contact us on (01234) 916125

Step 1: Position & drill fixing holes

Using the drill template provided, position and mark fixing holes and cable entry prior to drilling (rear entry only)

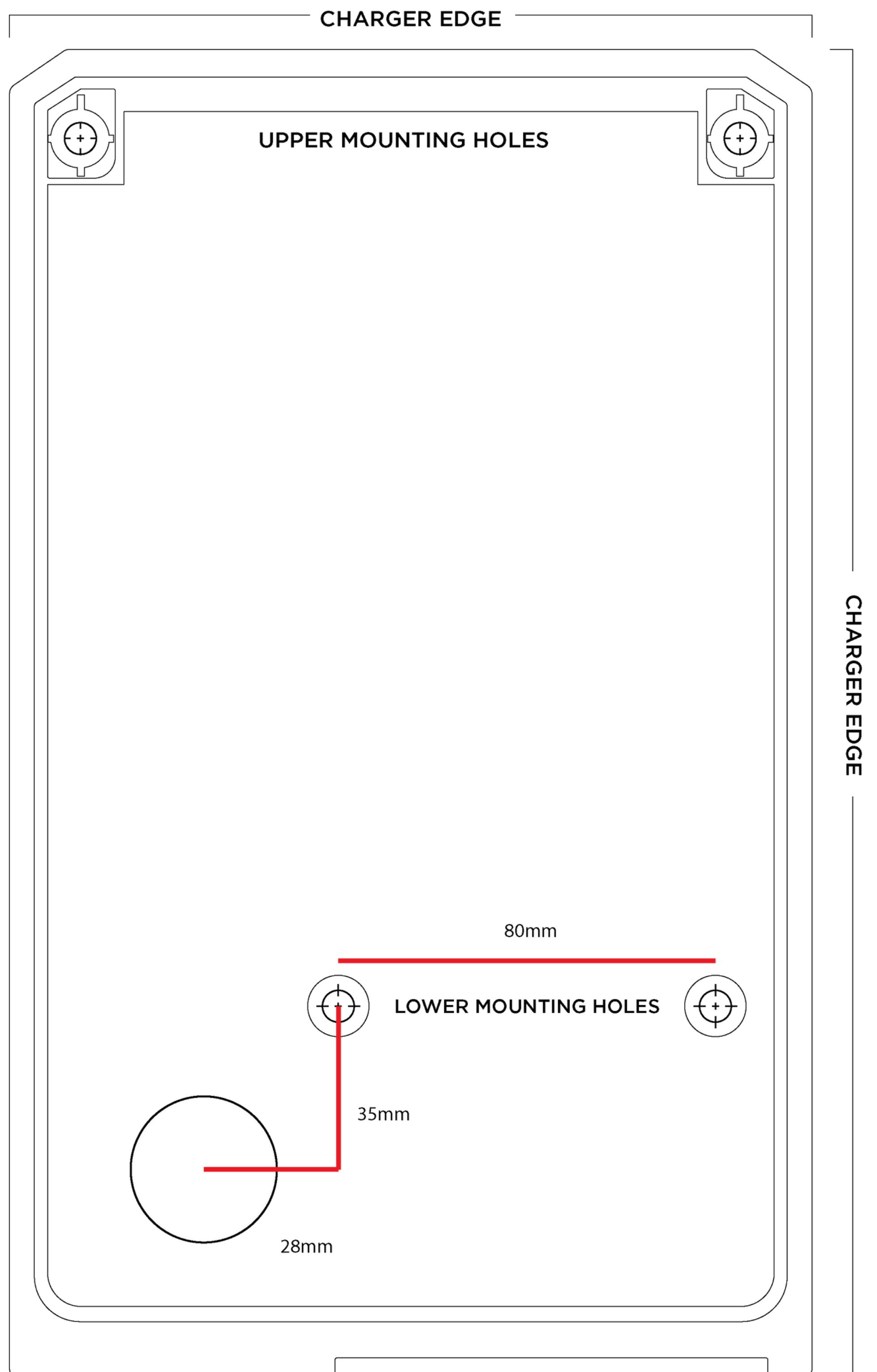

To download and print a to-scale drill template scan here



Ensure you print on A4 paper

PLEASE USE SEAL WASHERS PROVIDED WHEN MOUNTING CHARGER

Step 2: Remove trim

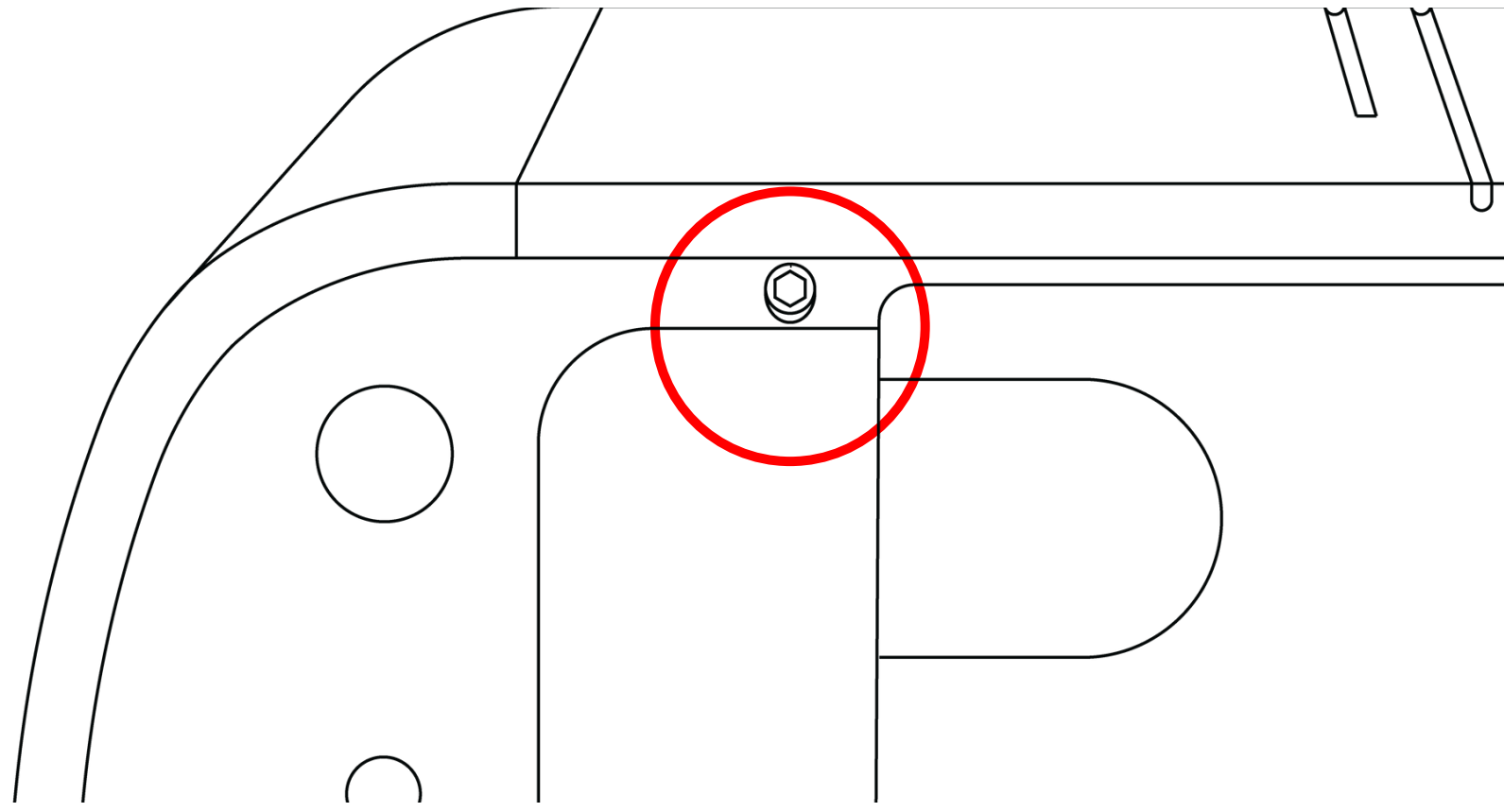

Using a 1.5mm Allen key loosen the angled grub screw on the underside of the charge point to release the centre trim

Grub screw does not need to be completely removed

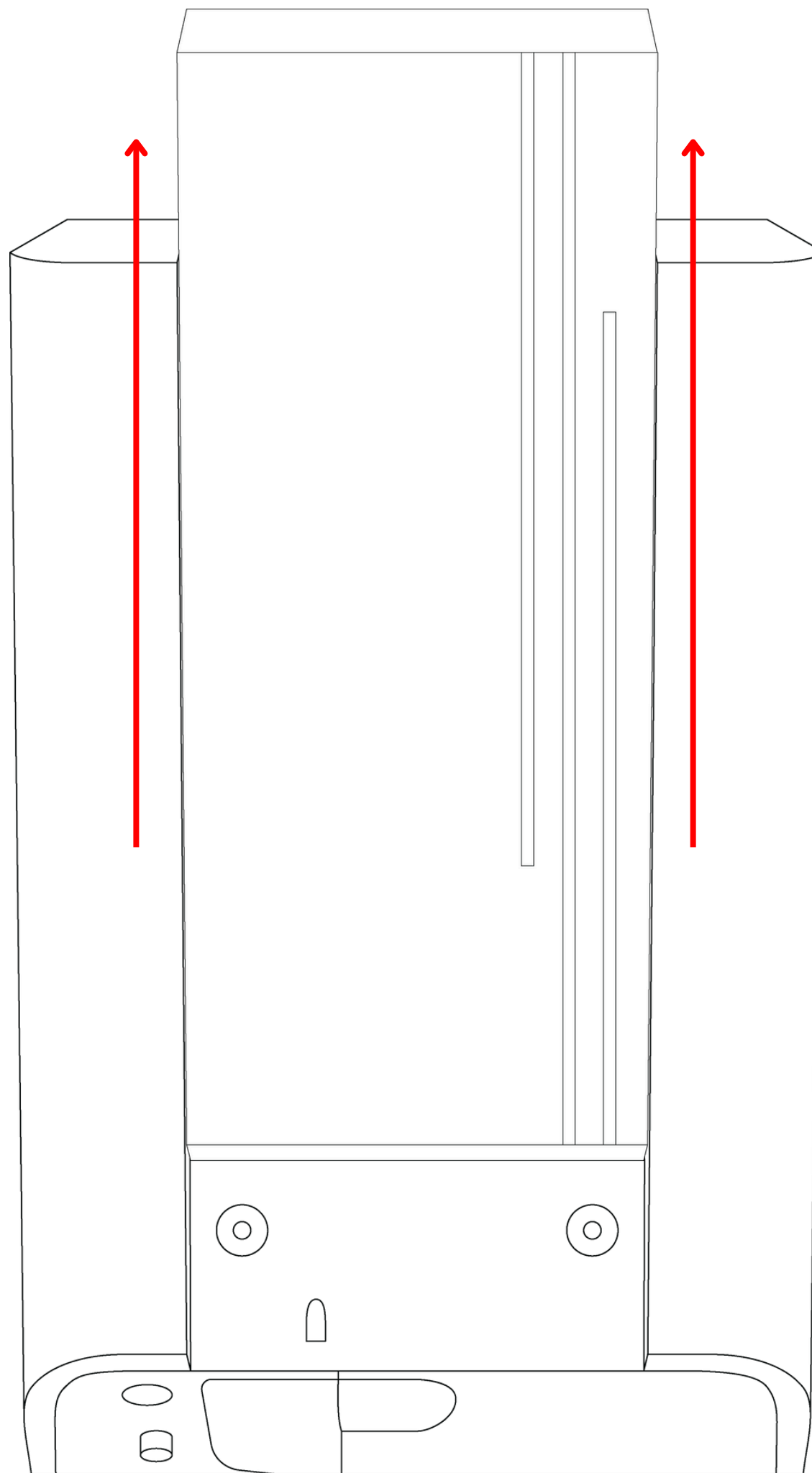

With the grub screw loosened, apply a small amount of pressure upwards to slide off the centre trim

Step 3: Remove casing

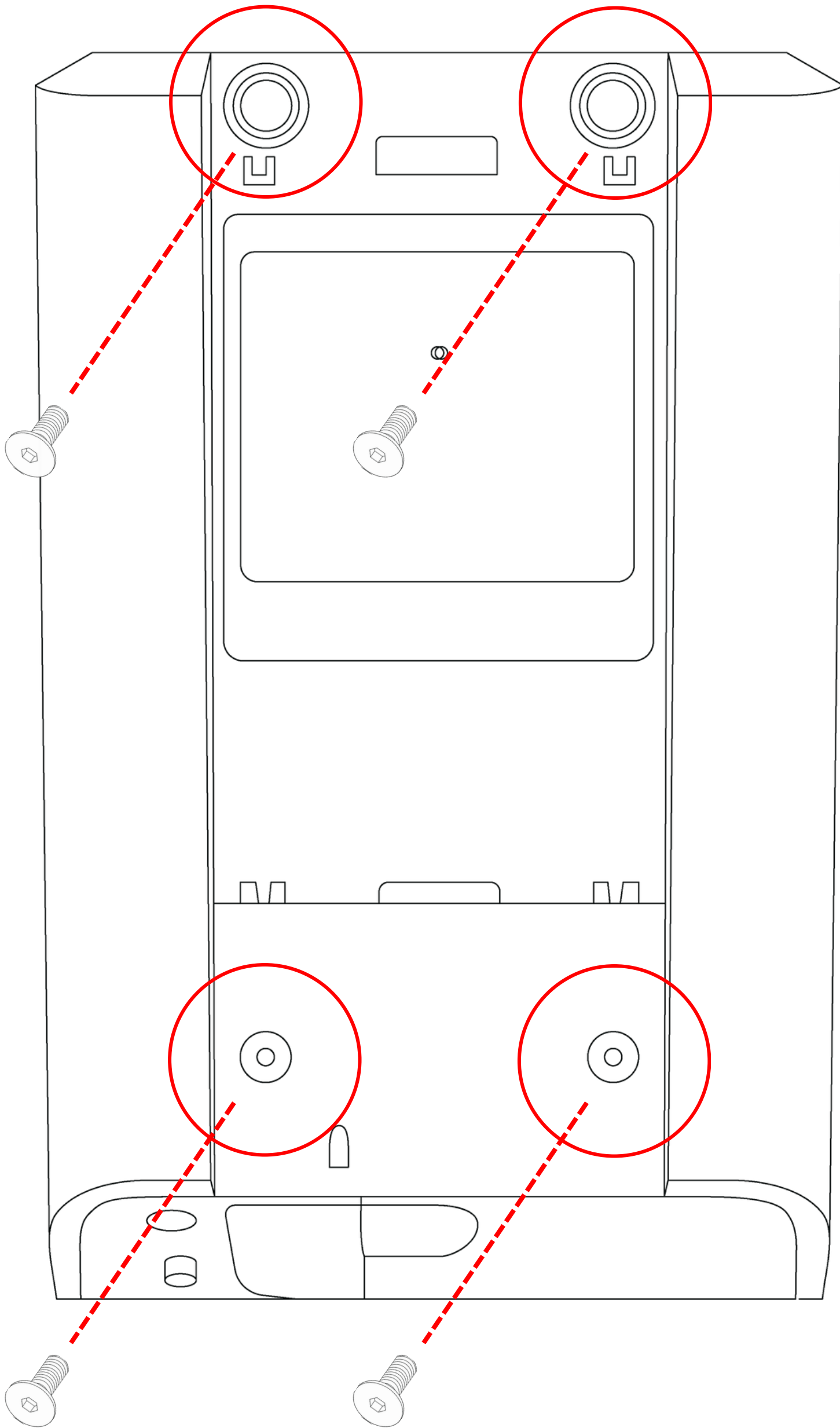

Using a T-25 Anti-Tamper Security Bit loosen and remove the 4x counter sunk screws to release the casing

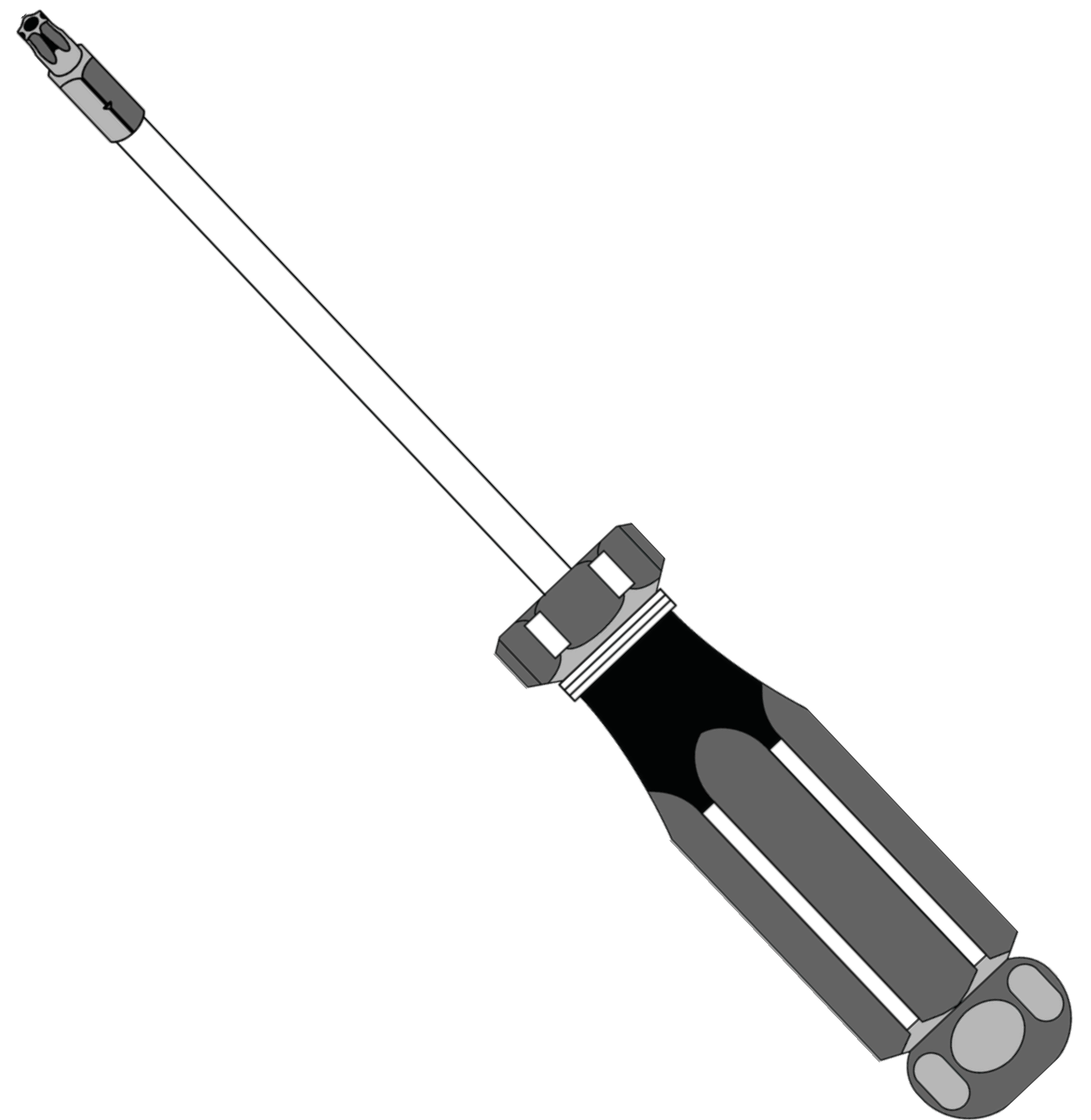

Please avoid using any battery operated drills to remove screws

Step 4: Deciding a cable entry

Cable can enter the unit from 2 positions:

1-bottom entry

2-rear entry

See steps 5a and 5b on requirements for cable entry

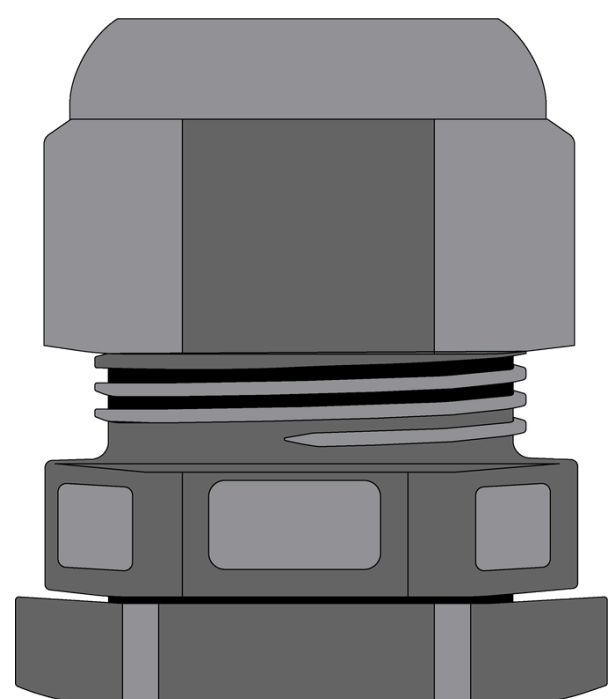

1x 25mm compression gland provided for power supply cable

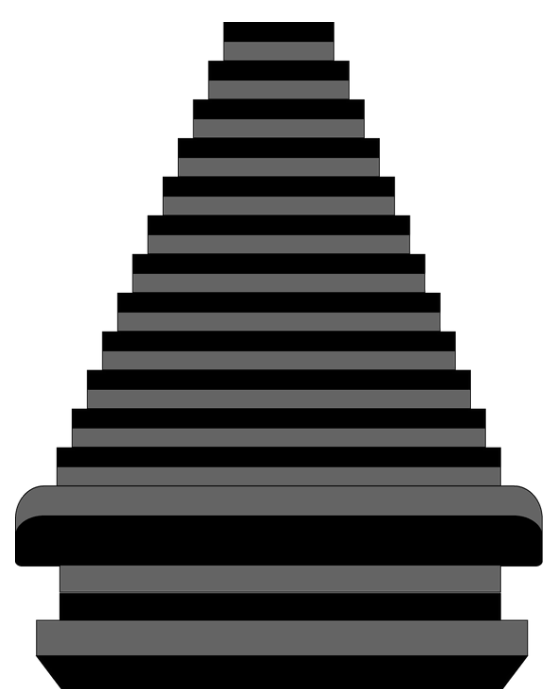

1x 25mm Step Grommet provided for any separate data cable

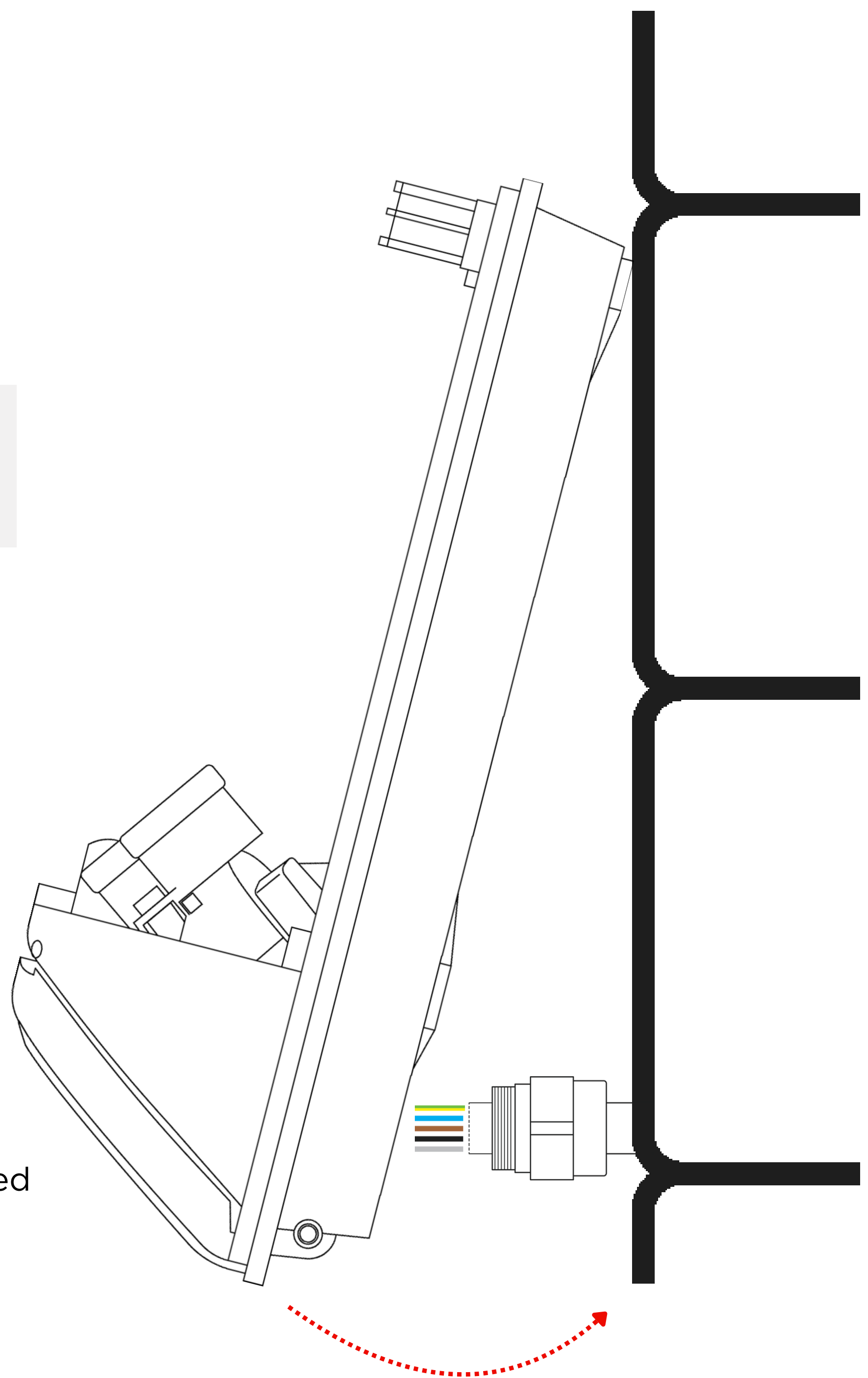

Note: The alternative hole with the cone grommet can be used for a separate data cable if applicable

Note: Any cables entering the unit should be adequately sealed

Step 5a: Supply cable bottom entry

Pre-install the cable gland to the specifications below

Remove gland lock nut ready for the supply cable to be fitted to the charger

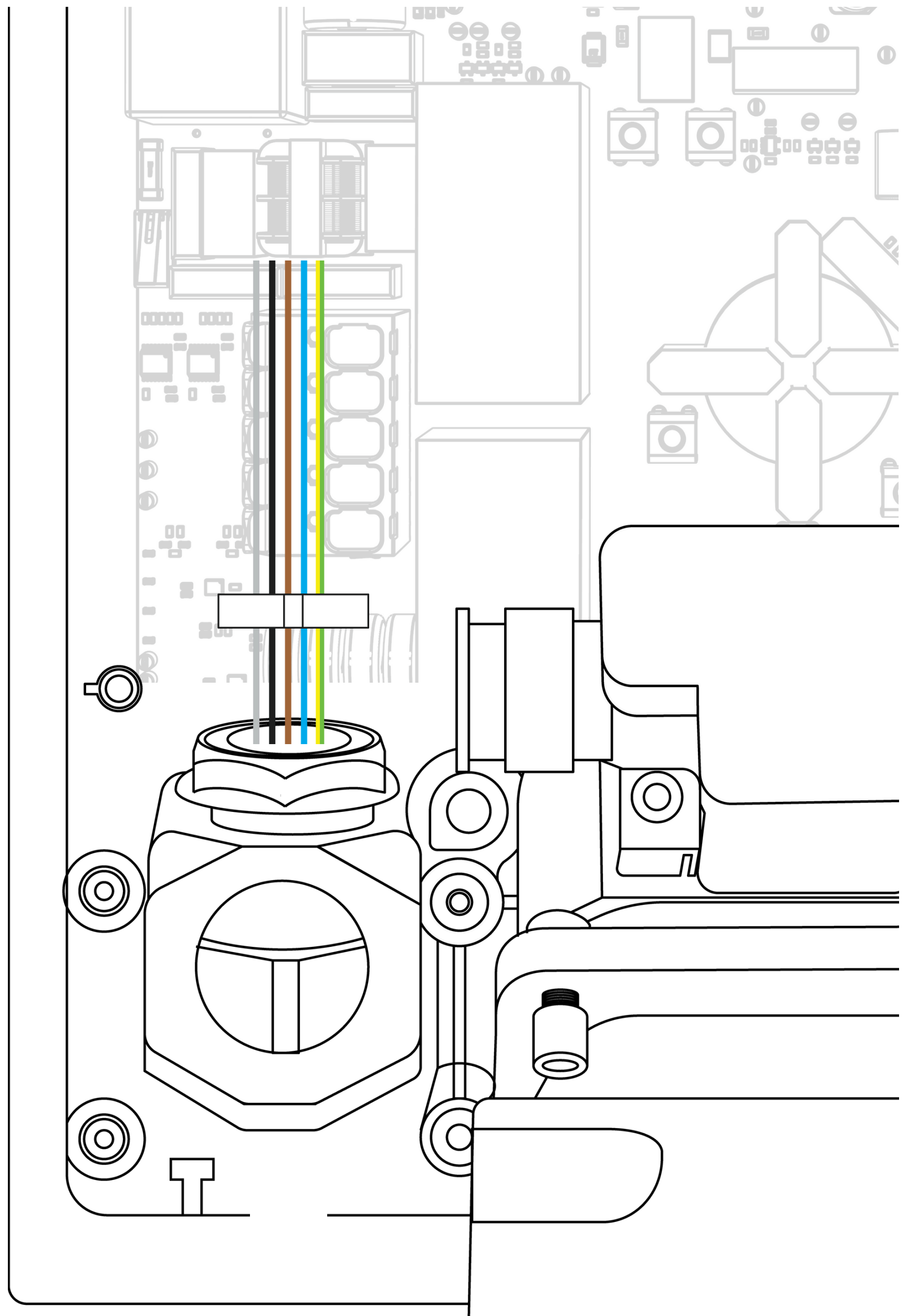
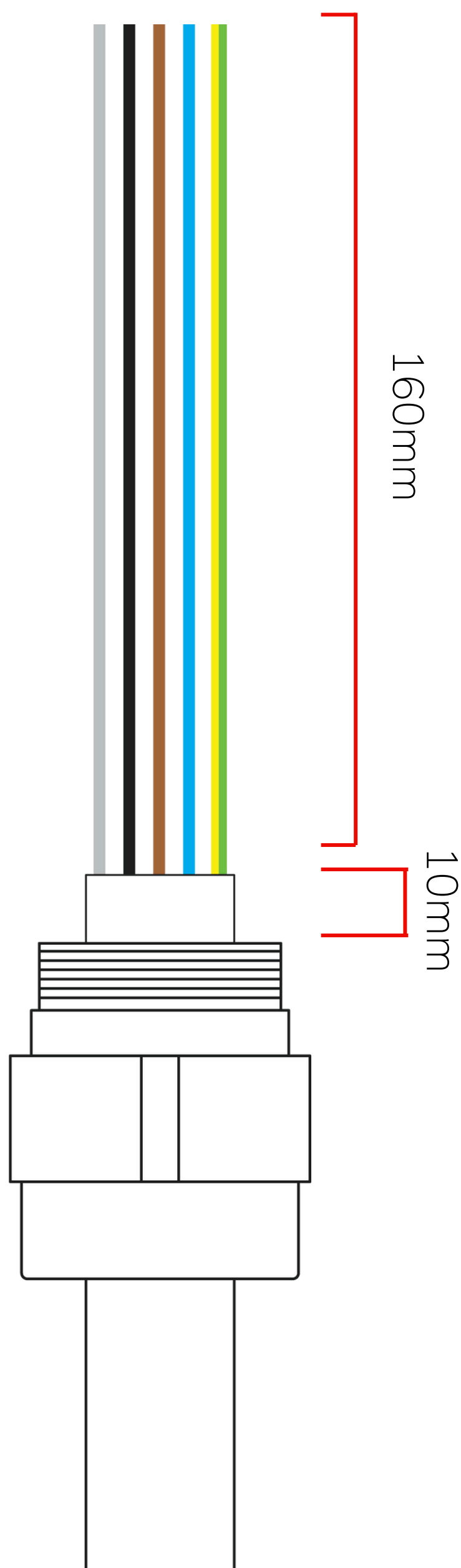

Loosely mount the fixing screws to the top two mounting positions of the charge point

Note: This will ensure you can fit the bottom entry gland and supply cable correctly

Step 5b: Supply cable rear entry

Remove locknut in preparation for the charge point to be installed over the gland

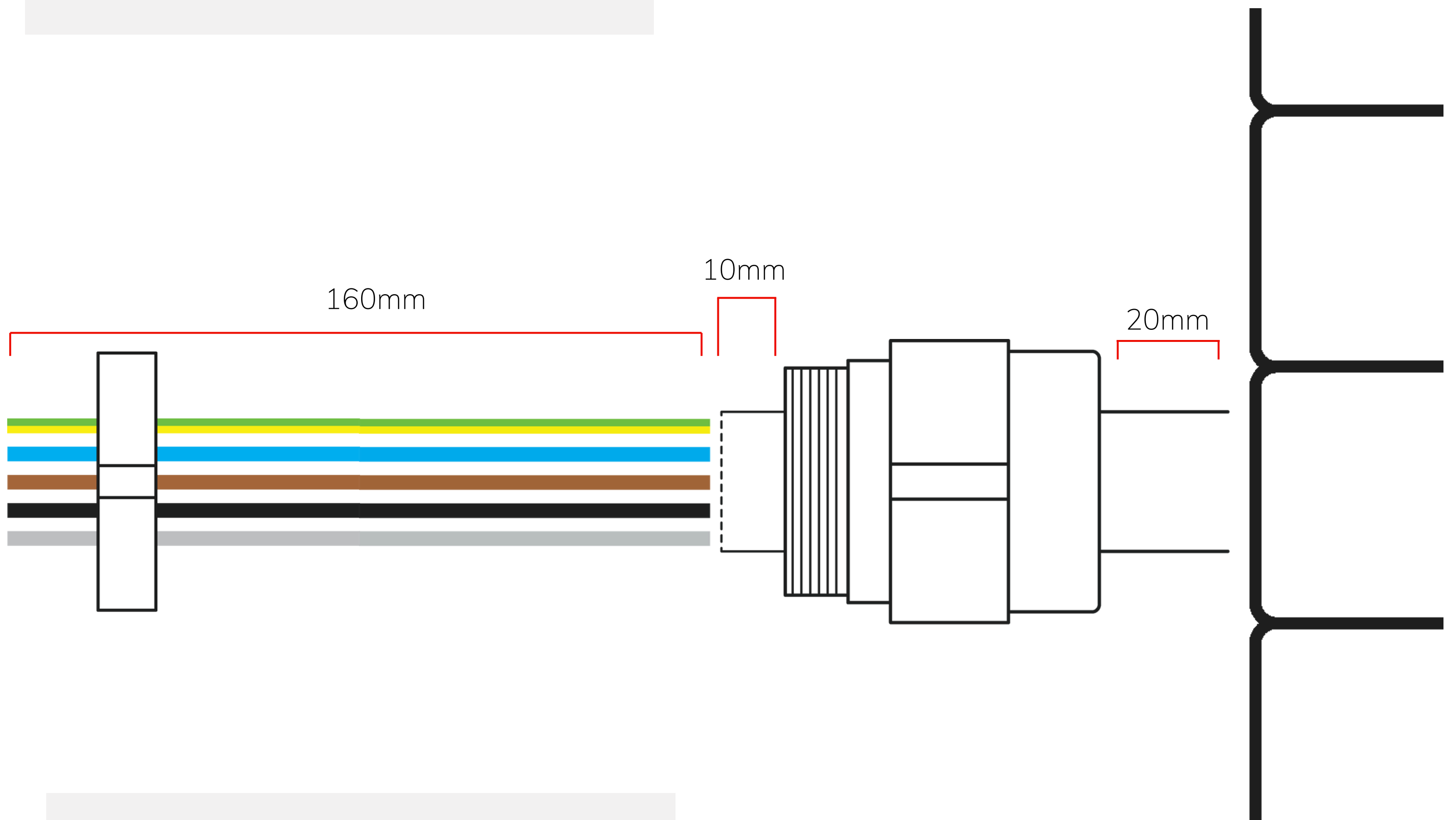

The gland needs to have a 20mm gap between the wall and the back of the gland

Allow 10mm of uncut outer sheathing at locknut end

Note: Fit and tighten gland onto supply cable before attempting to mount charge point to wall

Step 6: Sensor Cable Entry

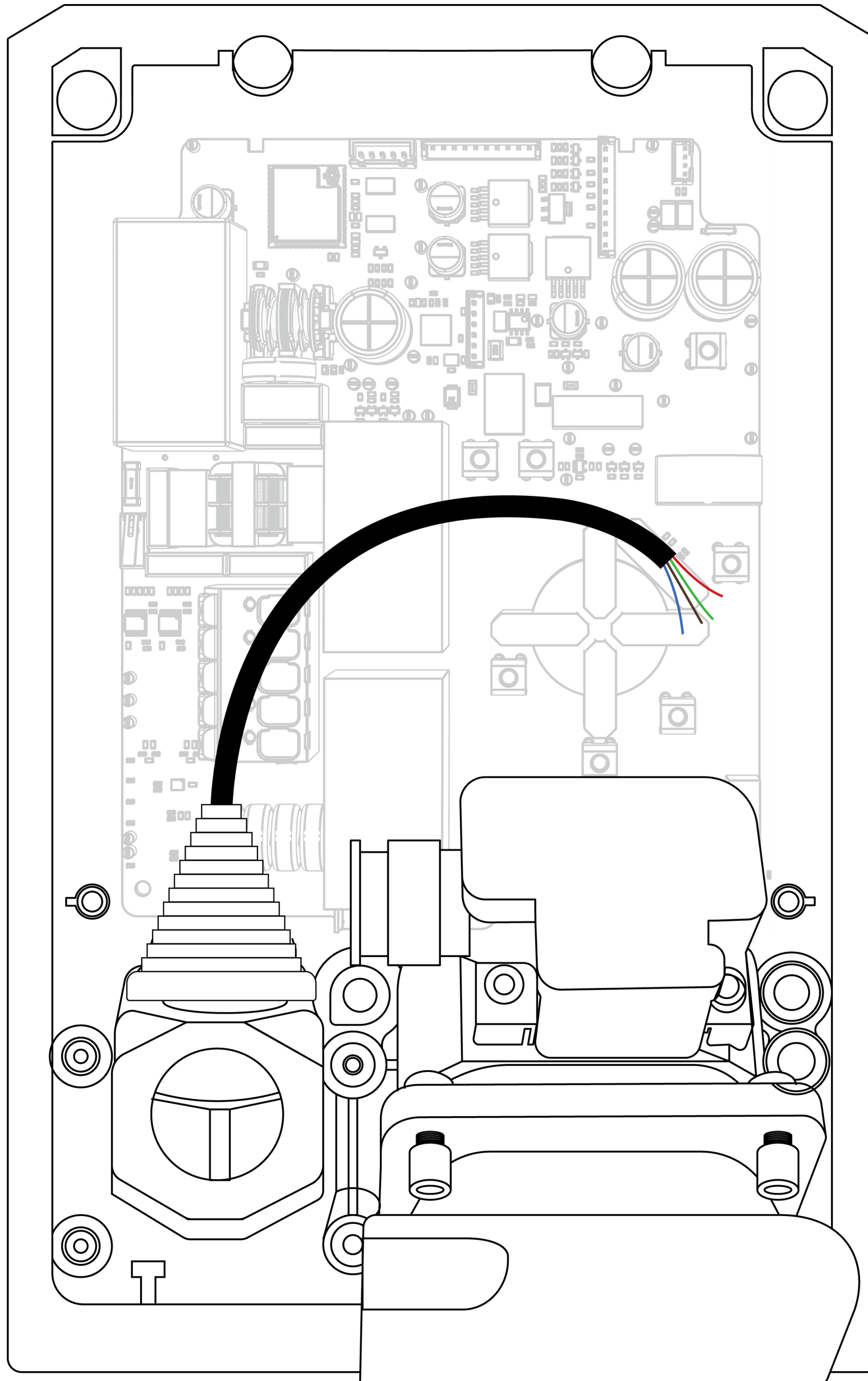

Install cone gland in the remaining cable entry

Make small piercing in the gland's tip and pass the data cable through, ensuring it has a tight seal

Step 7: Mounting to the wall

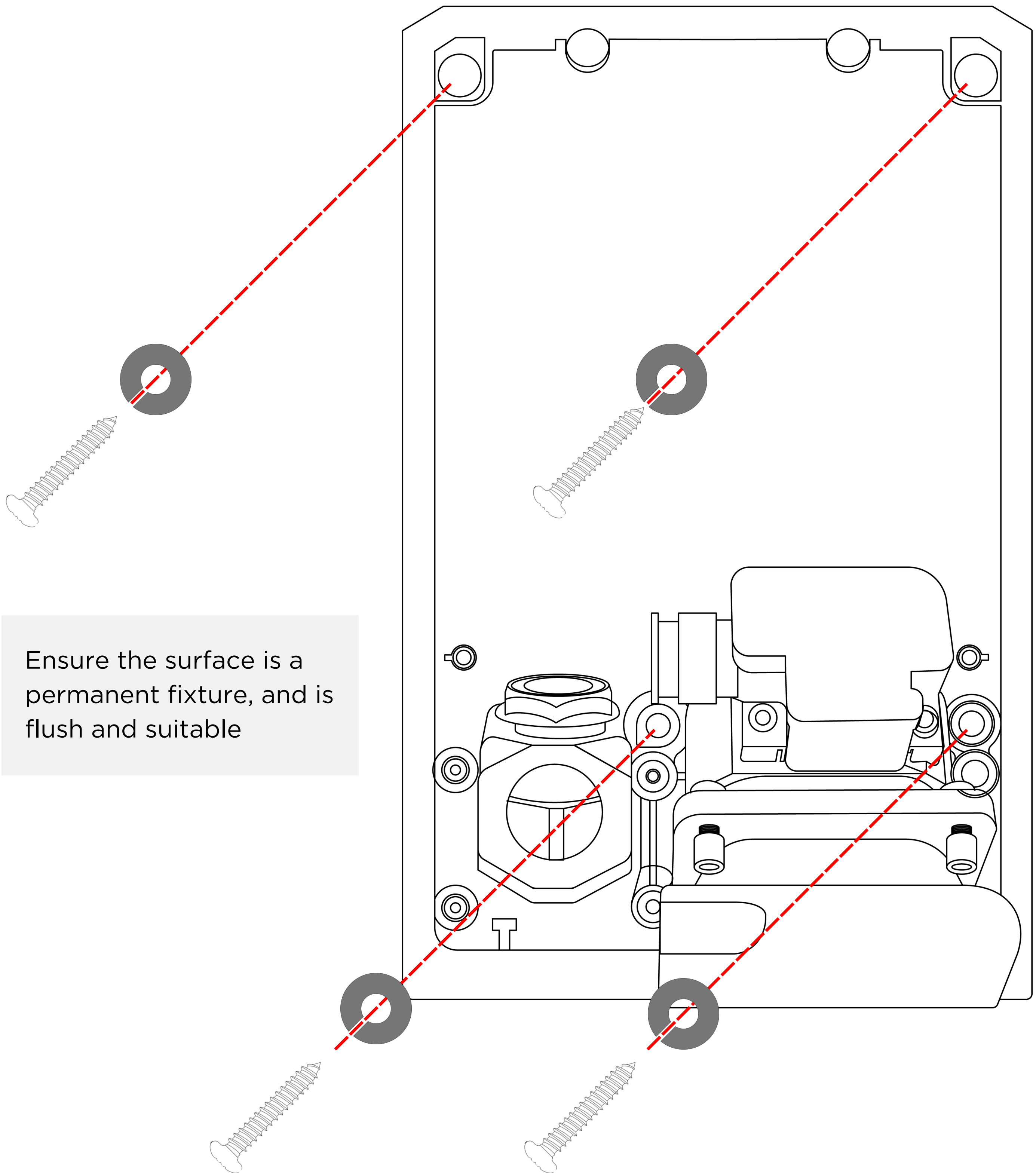

Ensure the surface is a permanent fixture, and is flush and suitable

The 60mm screws provided may not always be suitable for the surface material being fitted to

Use the 60mm mounting screws and seal washers provided to mount the unit to the surface

Step 8: Terminate Sensor Cables

Single phase

| 1 | 2 | 3 | 4 | 5 | 6 |
|-------|-------|-----------------|-----------------|-----|-----|
| Grid+ | Grid- | Advanced Solar+ | Advanced Solar- | N/A | N/A |

3-phase

| 1 | 2 | 3 | 4 | 5 | 6 |
|----------|----------|----------|----------|----------|----------|
| Grid+ L1 | Grid- L1 | Grid+ L2 | Grid- L2 | Grid+ L3 | Grid- L3 |

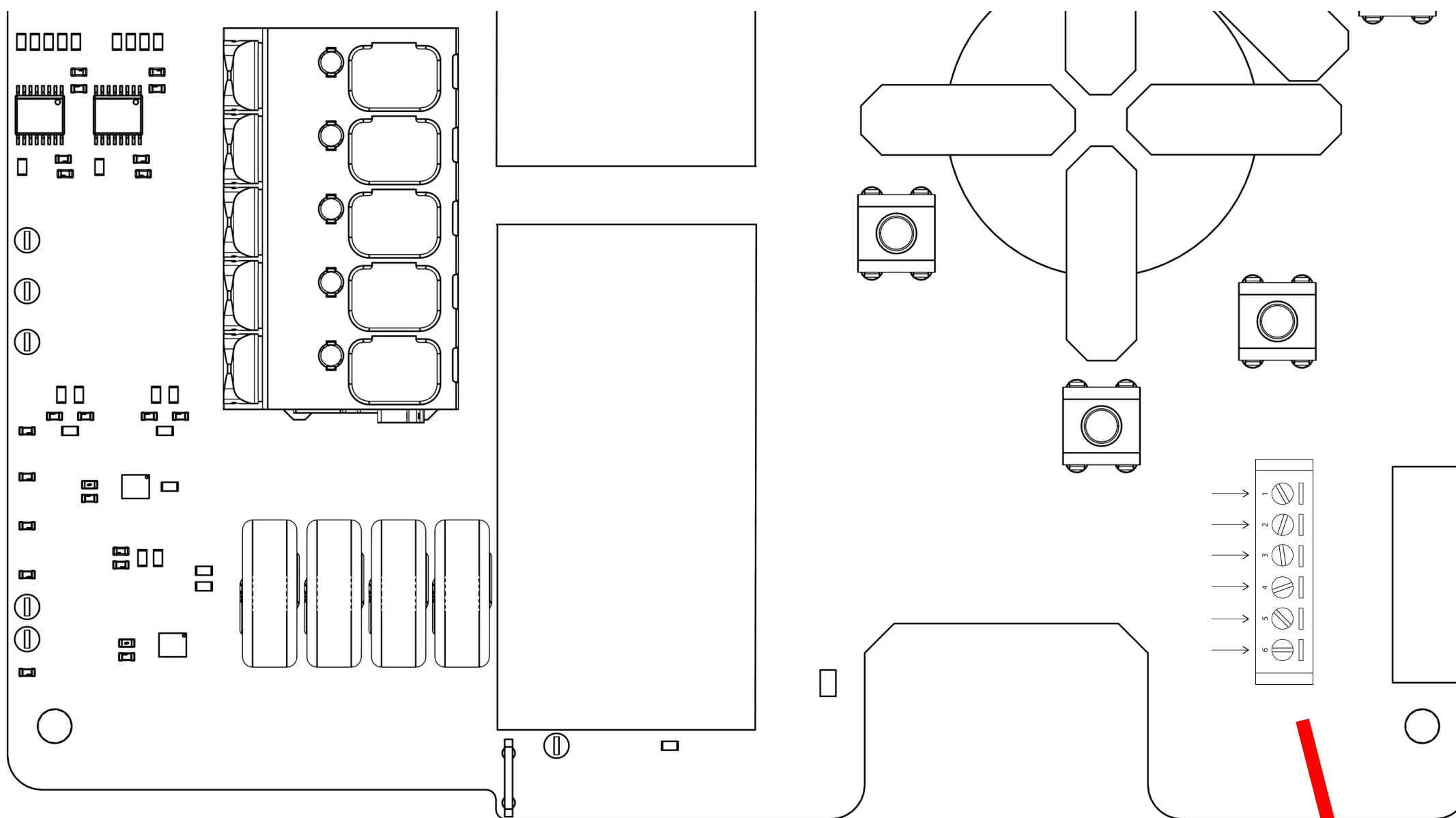

CAT6 shielded data cable recommended

Please follow commissioning guides for load limiting and solar features

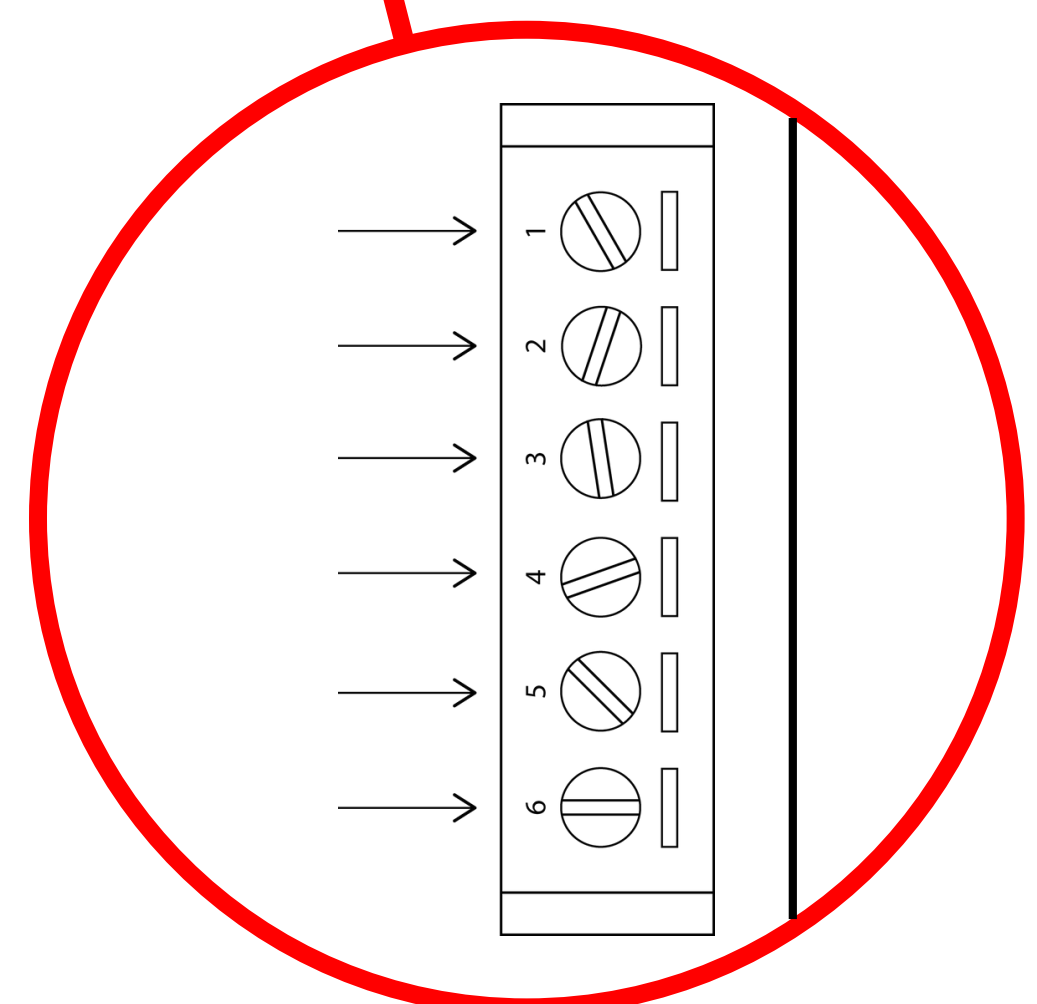

Step 9: Mains Supply Connection

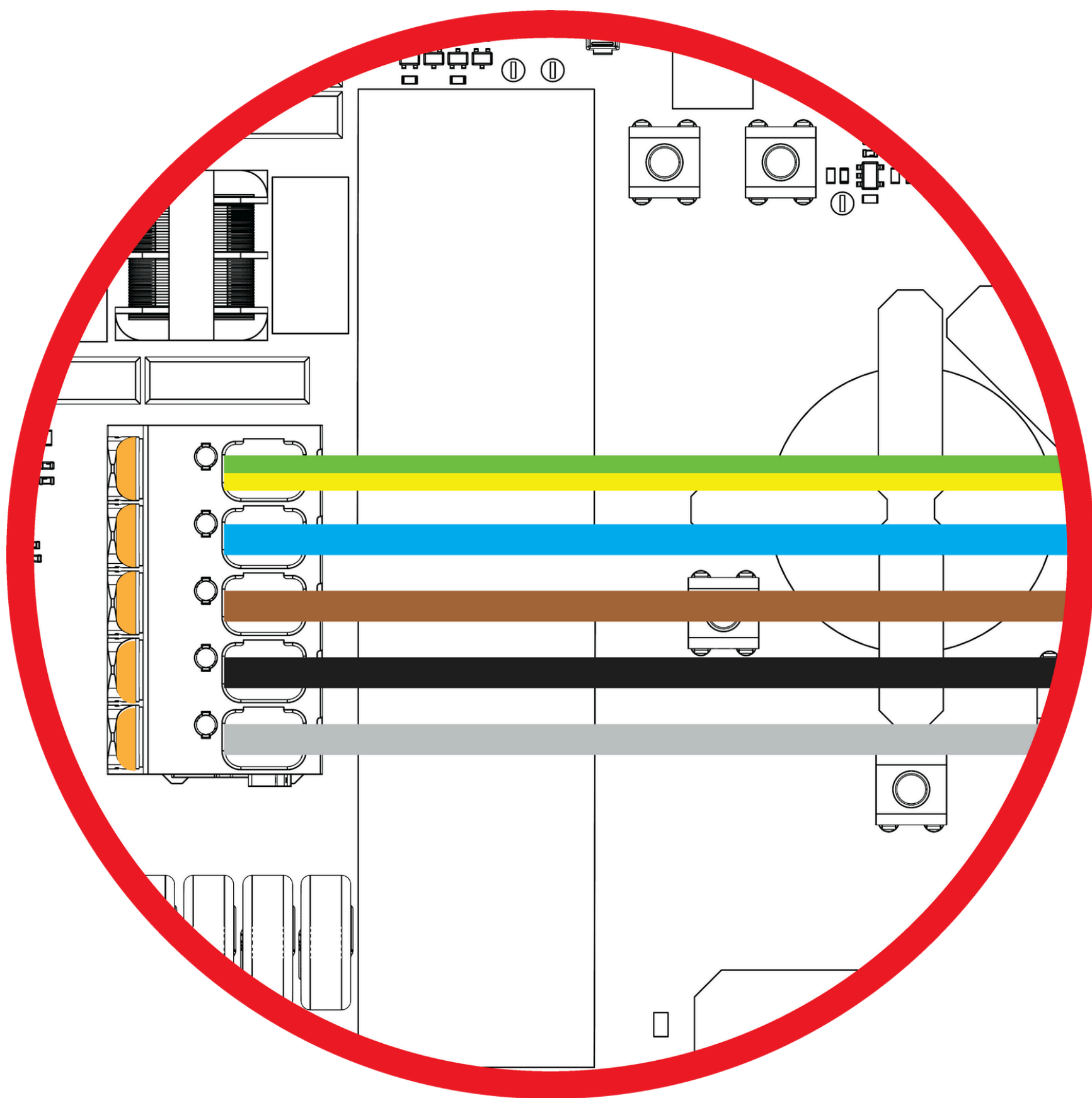

Open lever connector.
Insert cables. Close lever
and ensure there is a
noticeable click

| SUPPLY | 1 | 2 | 3 | 4 | 5 |
|--------|----|---|----|-----|-----|
| 1-P | PE | N | L1 | N/A | N/A |
| 3-P | PE | N | L1 | L2 | L3 |

Note: Any stranded
cables to be ferruled
and crimped

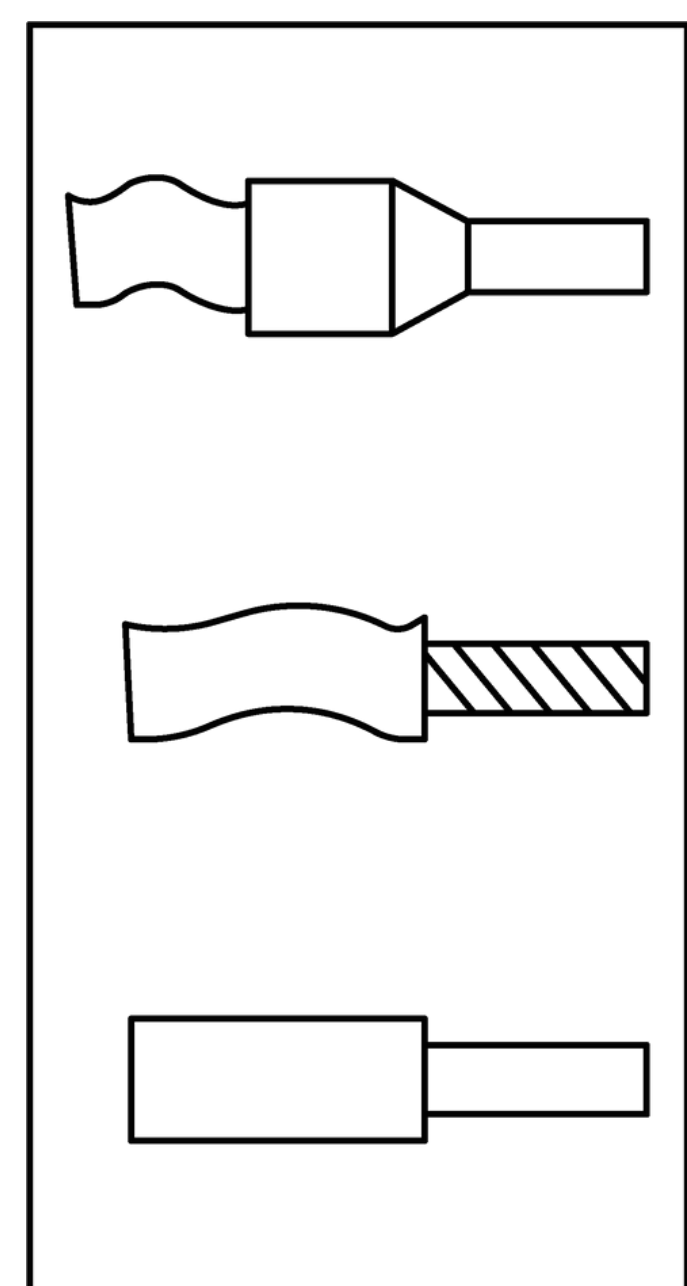

Strip length: 10mm

Step 10: Connect earth bond & fit front housing

Locate the earth fly lead which is attached to the charge point casing.

Attach cable to the spade connection which is located below the mains terminals on the PCB

Push into place

Carefully place the front casing onto the unit and screw into place using screws provided

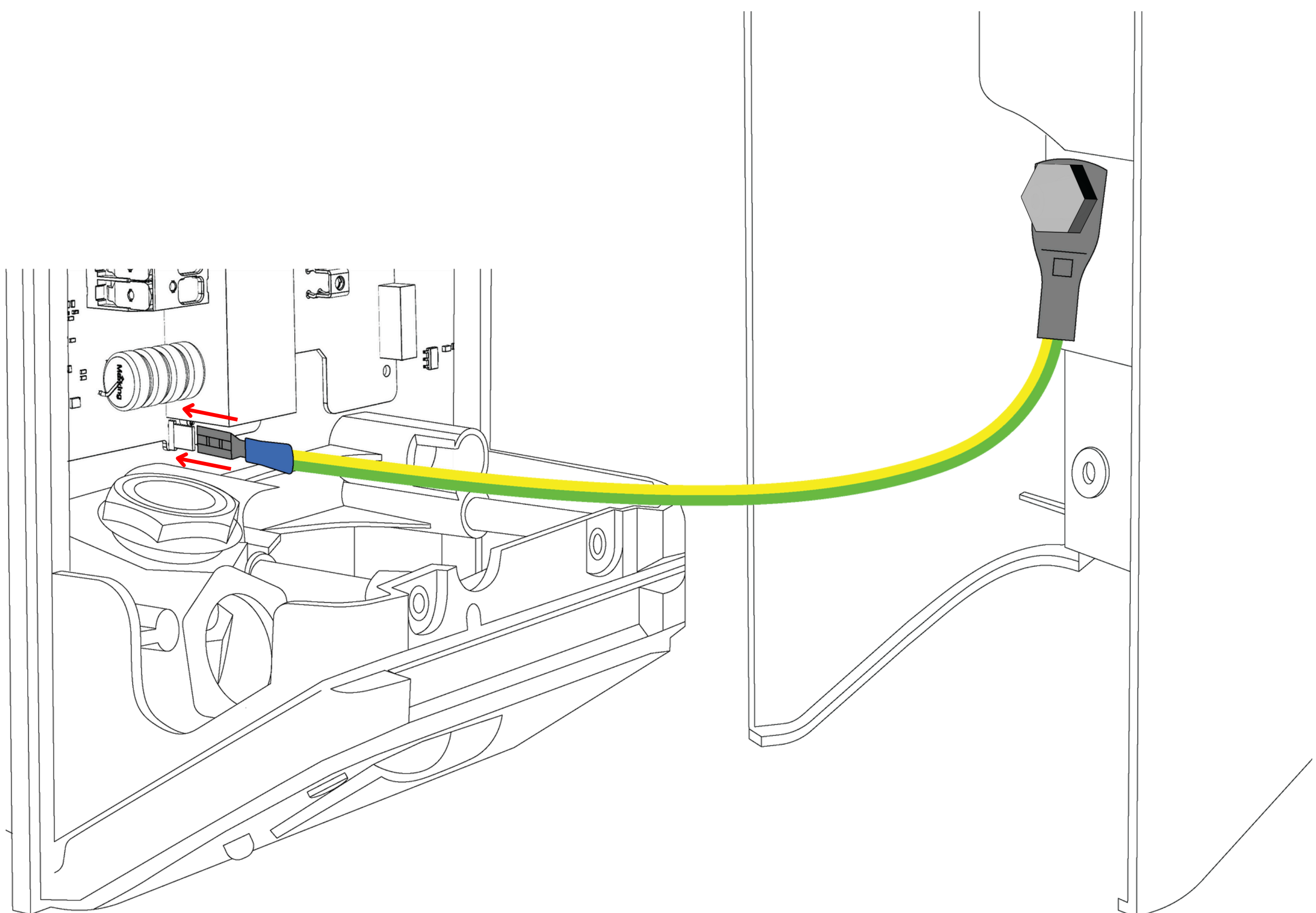

Step 11: Attach front insert

Once the front casing is in place, install and tighten the x4 T-25 screws to 1.5Nm

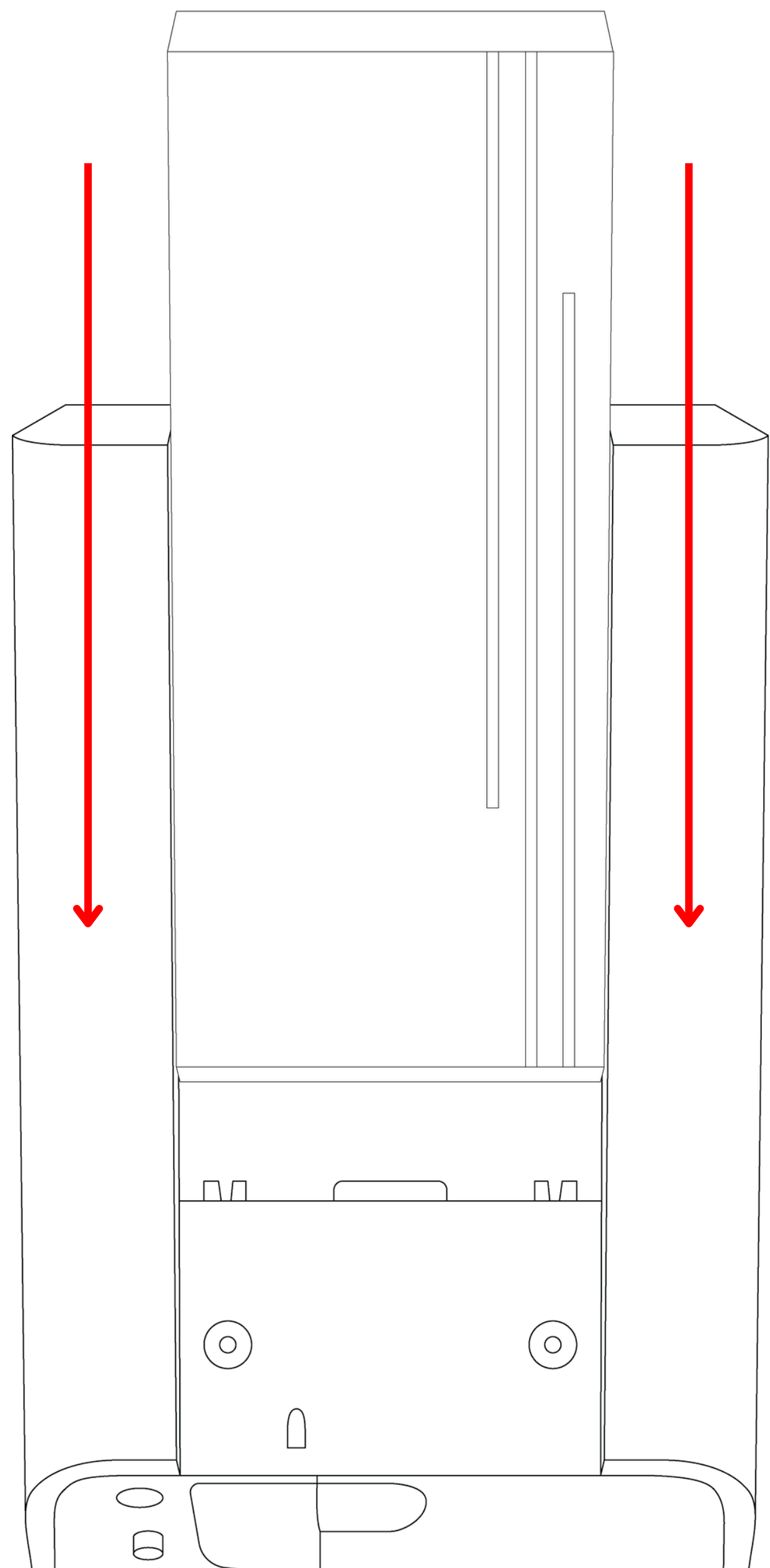
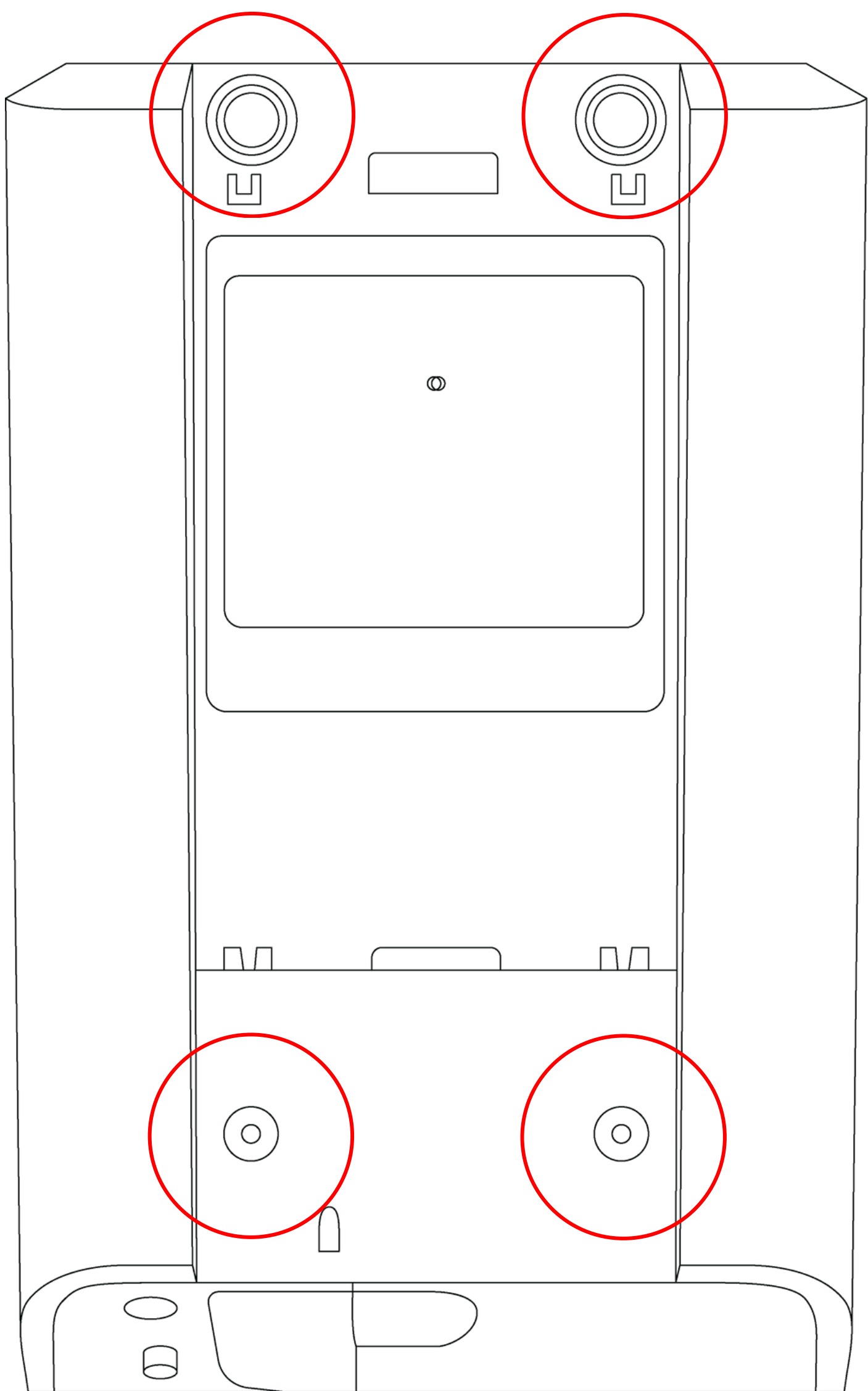

Slide the trim into place and tighten the grub screw until you feel slight tension

Commissioning an Andersen Charge Point

What you will need

A smart phone (iPhone or Android) with
Bluetooth enabled

A wireless broadband router and the Wi-Fi
password

The Boost button

During this process, you will need to use the Boost
button to put the charge point into set-up mode. The
button can be found on the underside of the charge
point on the left-hand side.



Commissioning

Open the Andersen App

Ensure you are logged out

Press the toolbox located in the bottom right of the screen

Follow the steps on the next screen to connect your charge point

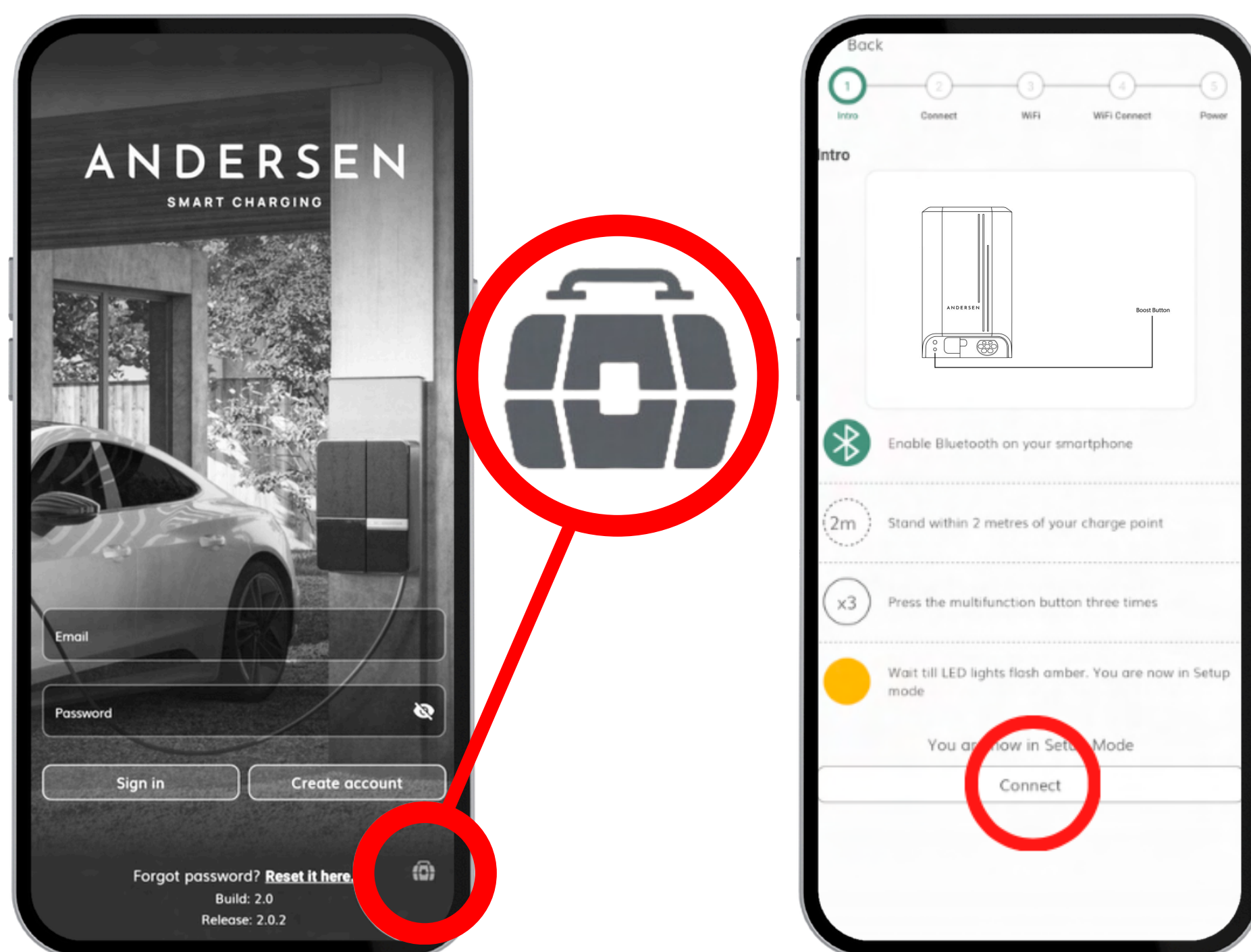

Scan the QR codes to download the Andersen app on both Apple and Android devices



Commissioning

On your charge point, find and firmly press the Boost button three times



You should now see the LED status light repeatedly flash cyan blue

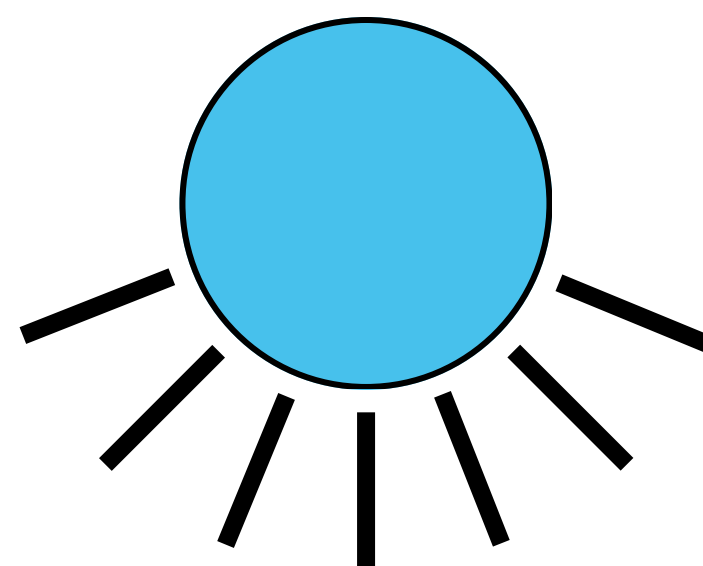

Commissioning

The Andersen App will start scanning for your charge point using Bluetooth. Tap the 'Connect' Button on the app to enter set-up

Once the Andersen App has found all available networks, please select the Wi-Fi you wish to connect to and enter the Wi-Fi password

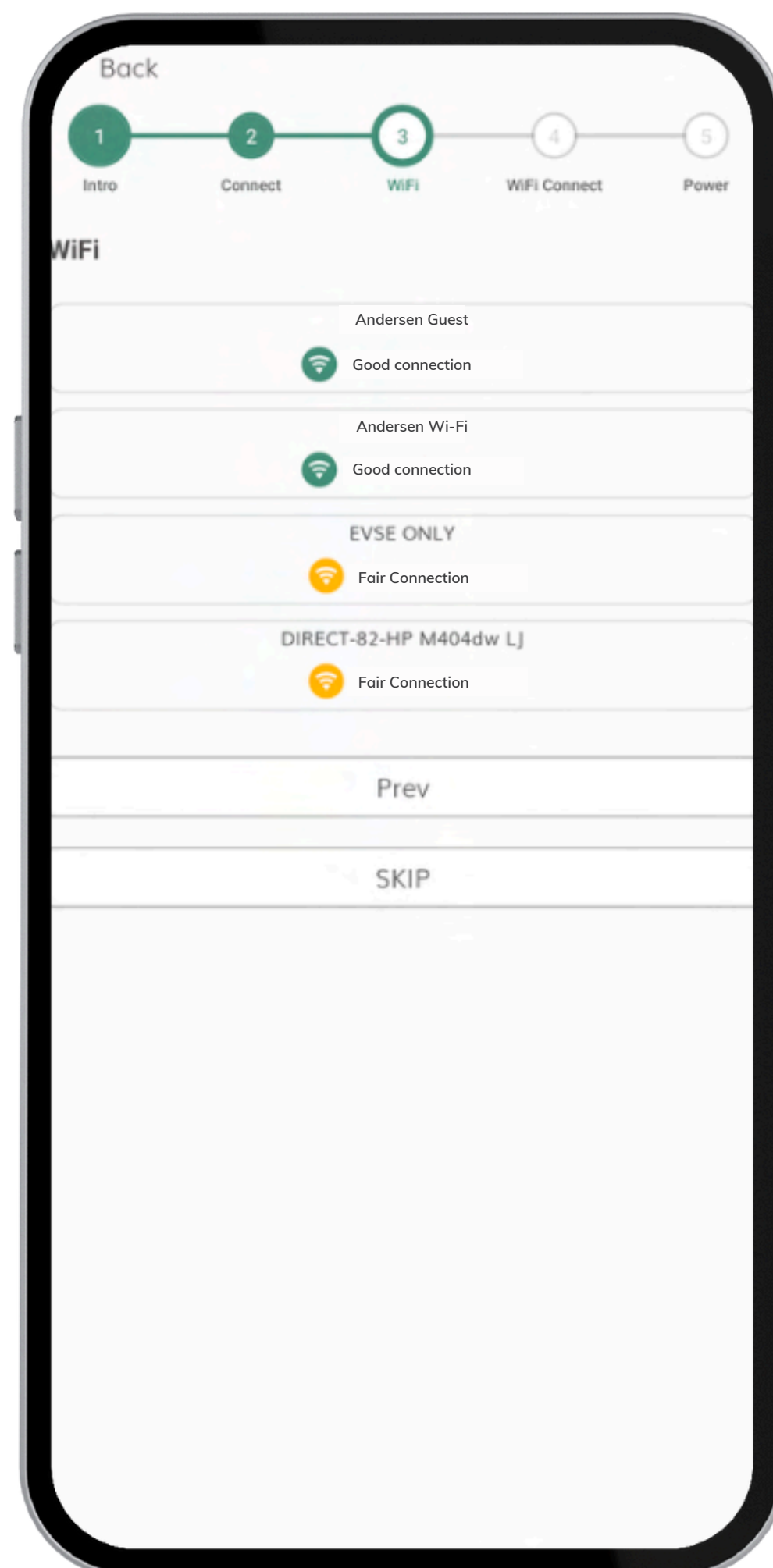
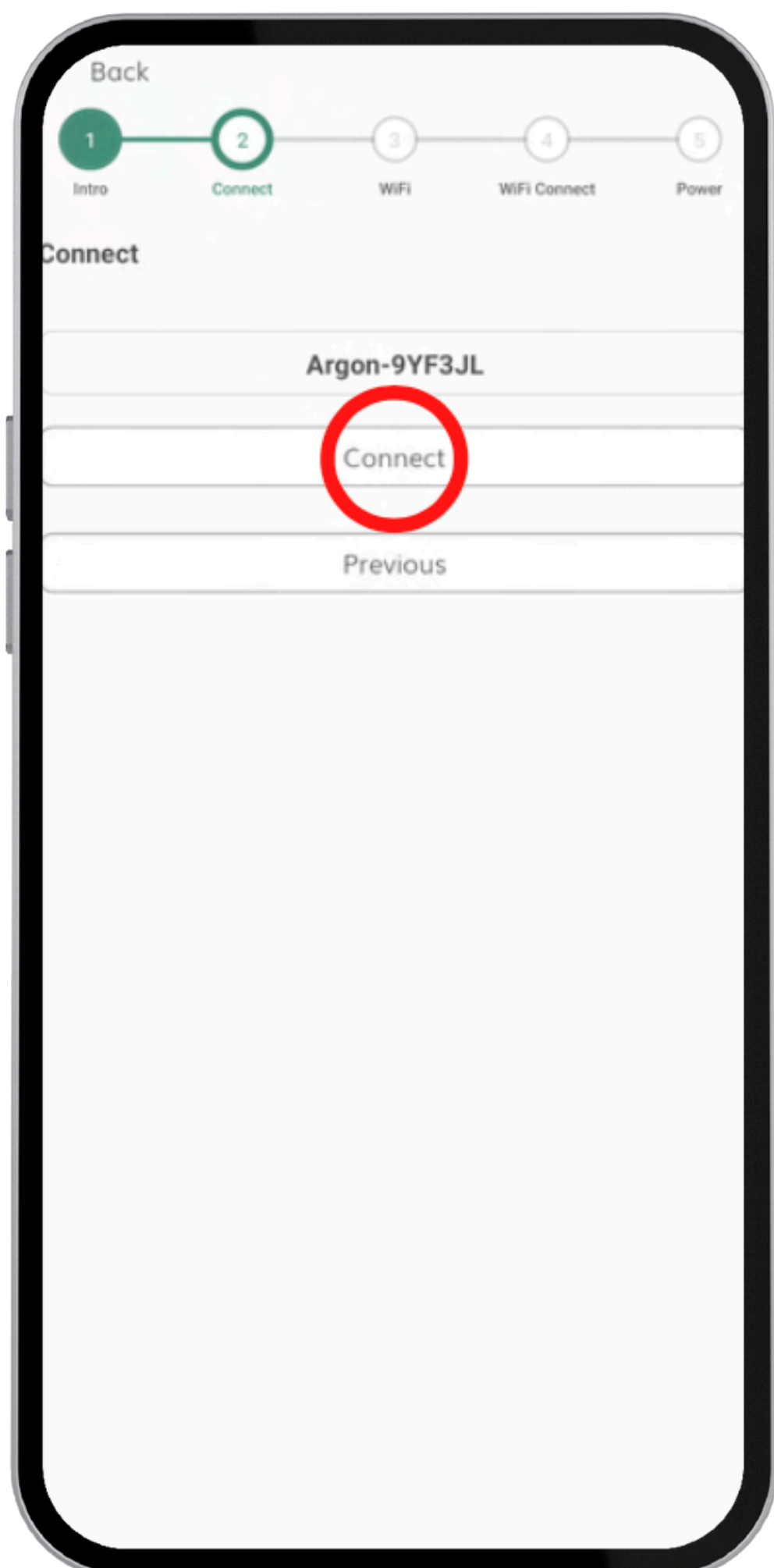

Commissioning

Once you have connected to the Wi-Fi network successfully, your signal strength will be displayed here along with confirmation of connection

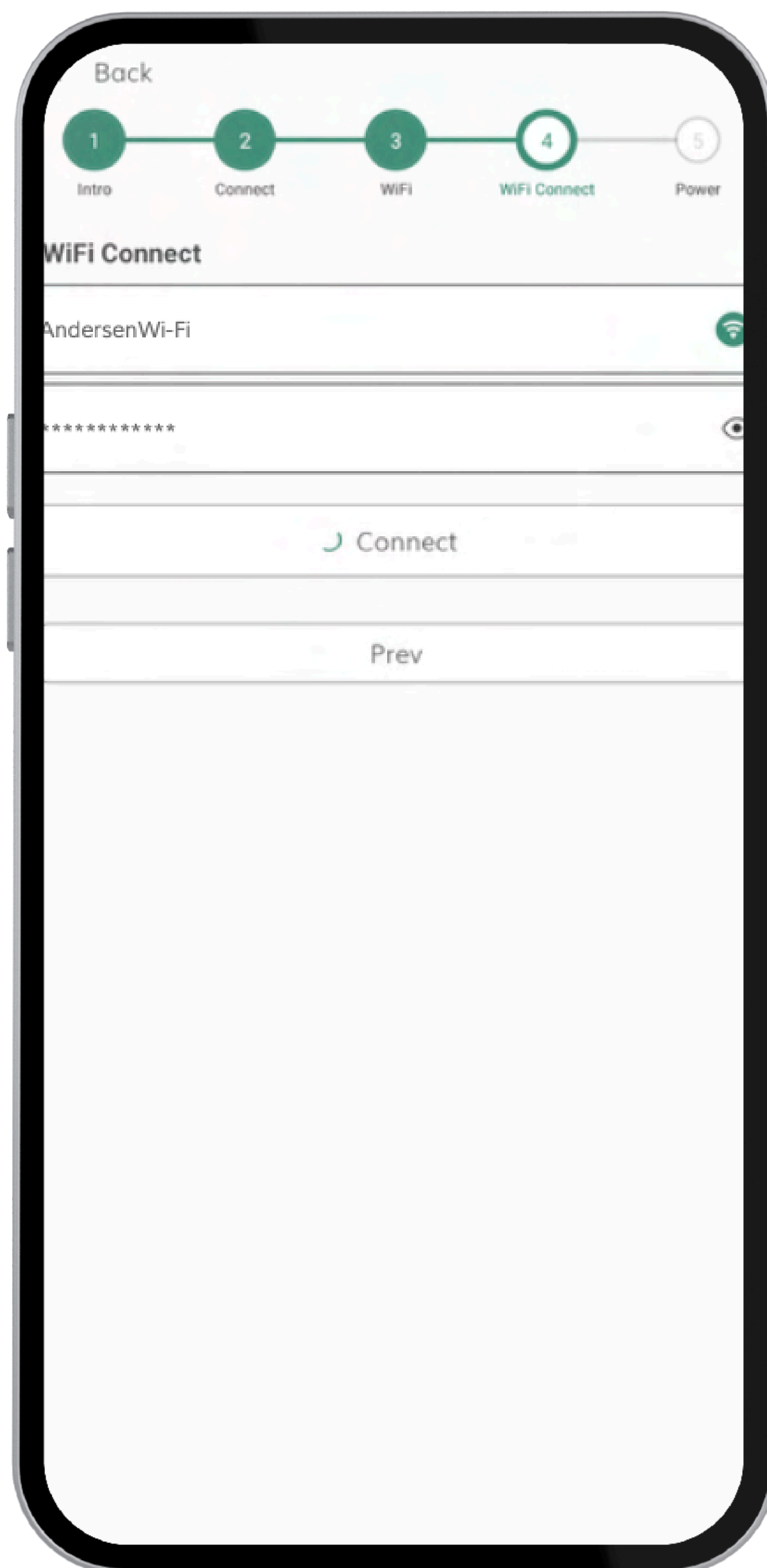

Commissioning

You will now be prompted to enter a PIN number to access the power settings. If you are a current Andersen affiliate you may already have this PIN

Alternatively, please contact us

**Telephone:
01234 916125**

Your installer commissioning is now complete.

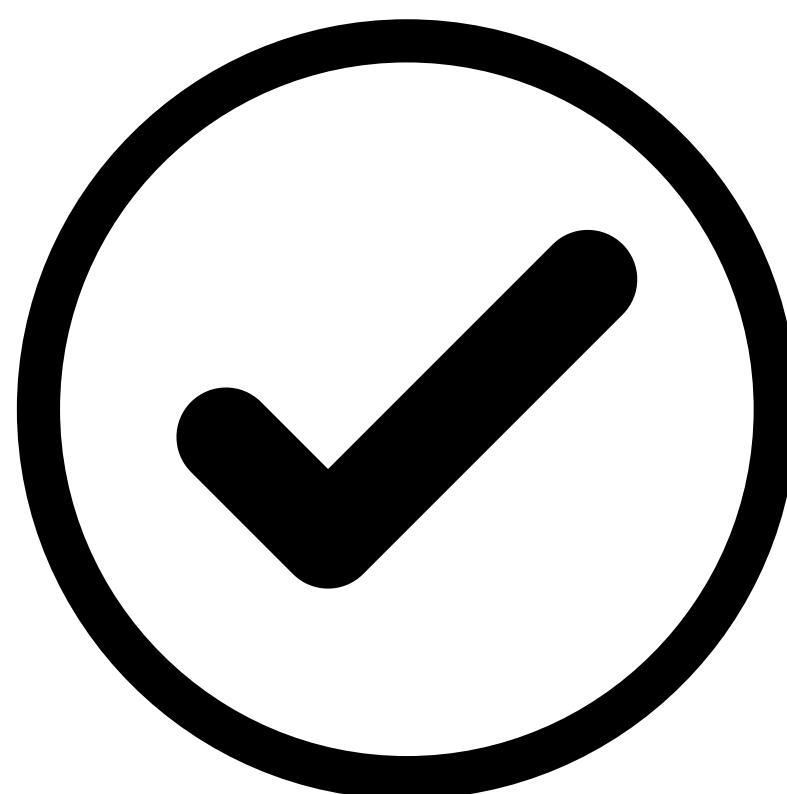

Become an Andersen Affiliate



Enhance your profits

Andersen affiliates have access to exclusive discounts - the more you sell, the more you earn



Market-leading support

As well as training and technical documents, our affiliate programme gives you access to our experienced technical experts, ready to help with any query you may have



Simplified business

The Andersen affiliate portal means managing your Andersen orders is easy, leaving you free to concentrate on your business

**We recommend you become an
Andersen affiliate**

**Please scan the QR code below to
submit an application to allow us to
fully support you**



CT CLAMP POSITIONS

Solar Basic / Adaptive Fuse

Position the CT clamp around a live conductor to monitor loads for the entire property and any generated export

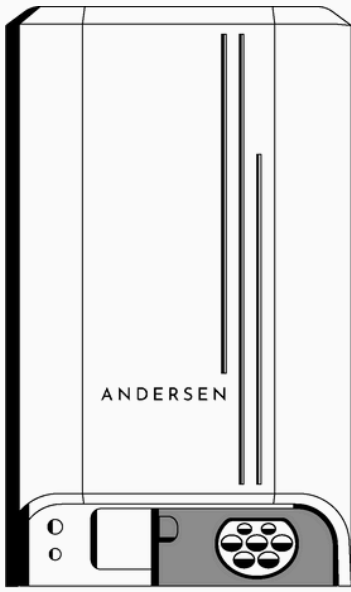
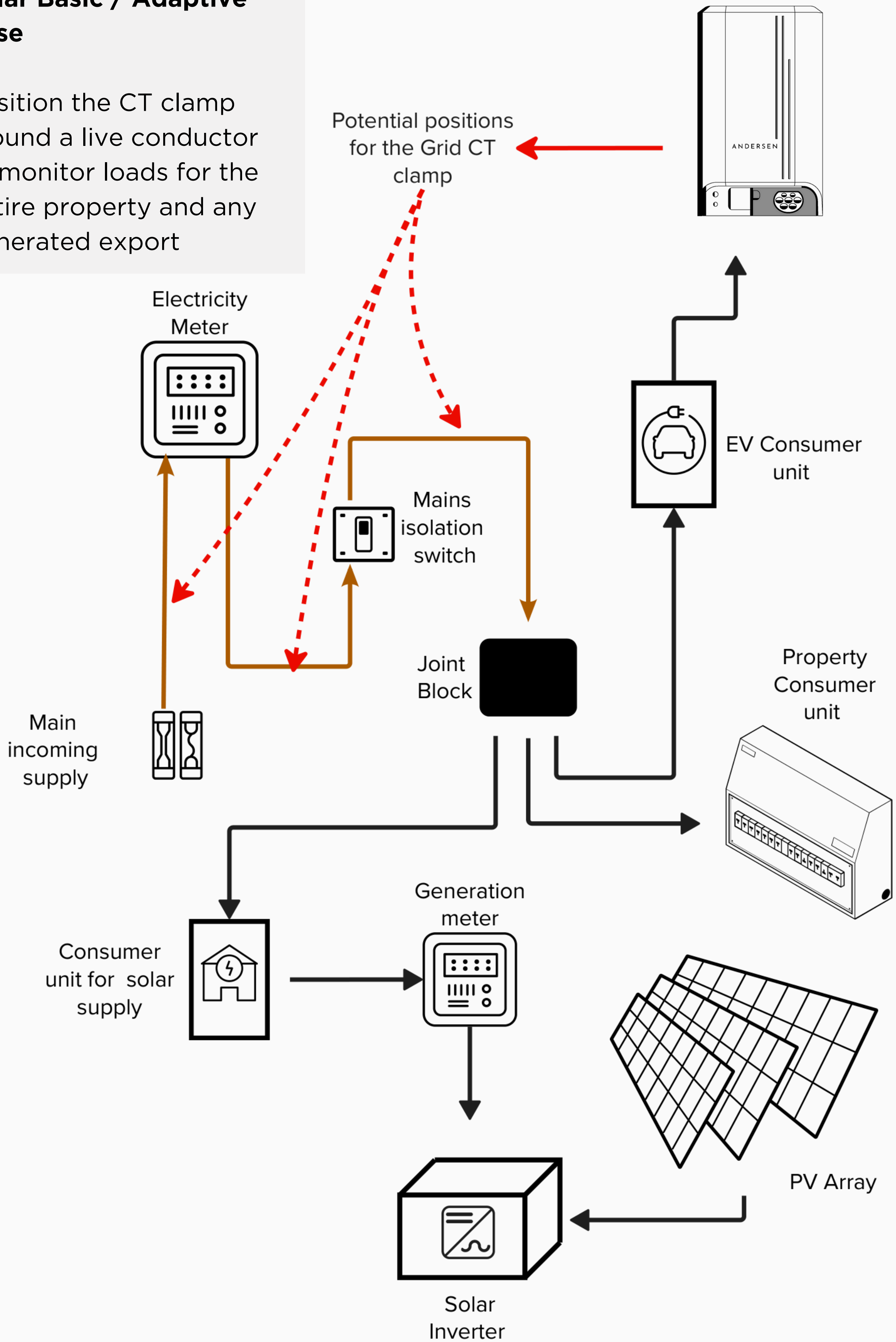

CT CLAMP POSITIONS

Solar Advanced

Position the Solar CT clamp around the live conductor to monitor load for solar generation only

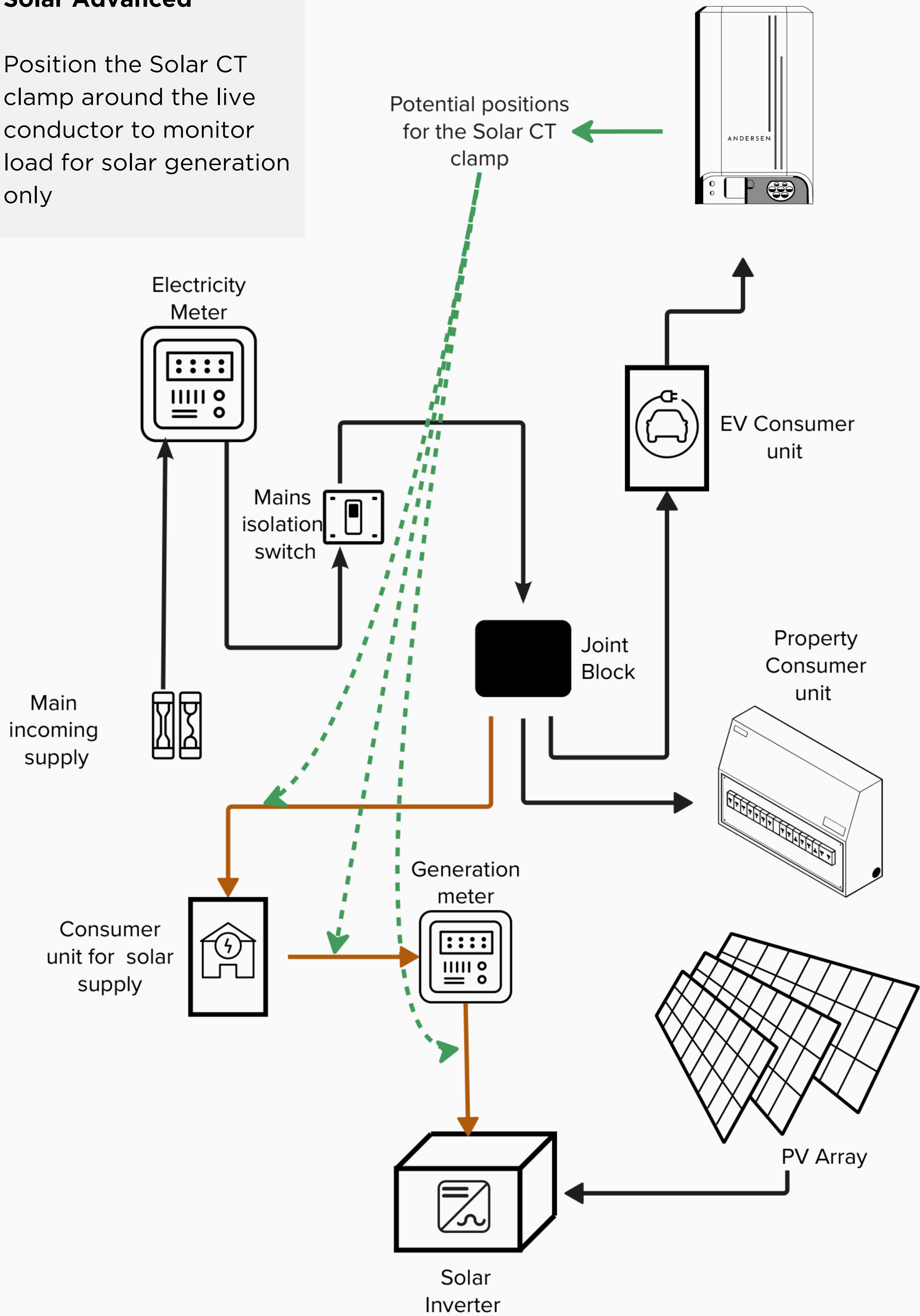

CT CLAMP POSITIONS

3-phase load limiting and basic solar

Position the CT clamps around the live conductors to monitor loads for entire property and any generated export

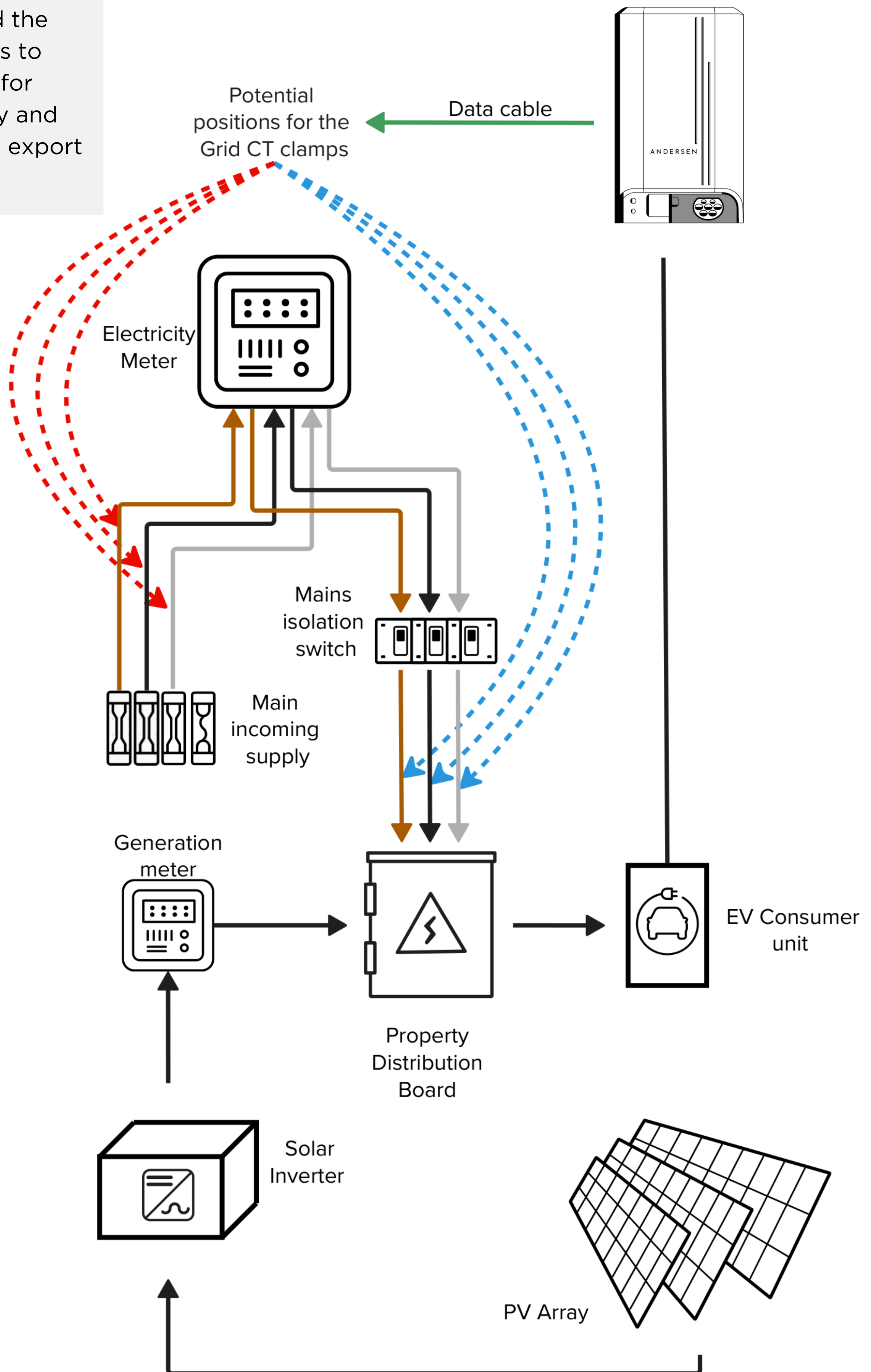

Andersen Quartz Technical Data

| | |
|--------------------------------|---|
| Mounting Location ¹ | The mounting wall must be capable of supporting at least four times the weight of the unit (3.4kg) and must be fire resistant. |
| Charging Mode | Mode 3 (IEC 61851-1 complaint communication protocol) |
| Display | RGB Status Lights - Socket Amenity light, White (Socketed version only). |
| Charging Current | Single Phase version, 6A to 32A Three Phase version, 6A to 32A per phase |
| Variable Current | 6A - 32A CT Monitored (Adaptive Fuse) |
| Connector Type | Type 2 Socket IEC 62196-2 compliant OR Type tethered cable IEC 62196-2 compliant |
| Compliance | RED 2014/53/EU, LVD 2014/35/EU, EMC 2014/30/EU, EN 61851-1:2019, EN 62196, EN 62955:2018, ROHS 2011/65/EU, WEEE 2012/19/EU, CE and UKCA Certified |
| Ingress Protection | Enclosure, core IP65 |
| Operating Specification | Humidity to 95% RH non condensing -25 Celsius to +40 Celsius |
| Security | Remote software enabled charge point locking, 128-bit data SSL AES encryption for smart connectivity, Bluetooth with TLS encryption |
| Fault Monitoring | Realtime health monitor system, start-up self-test, Earth monitoring, Welded contactor monitor, PME monitoring |
| Enclosure Core Material | Polycarbonate Blend |
| Finish Material | Coated Aluminium, optional Accoya insert |
| Shipped Weight | 12-14kg |

| | |
|---------------------------------------|---|
| Electrical Specifications | |
| Rated Power | 7.2kW (1-phase) 22kW (3 -phase) |
| Rated Supply Voltage | 230 VAC Single Phase 400 VAC Three Phase |
| Voltage Tolerance / Frequency | 230 VAC +10% -6% 50Hz 400 VAC +10% -6% 50Hz |
| Rated Current | 32 Amps |
| PEN fault detection | Conforming to 722.411.4.1 (iii) (iv) |
| Earth Leakage Protection ² | Internal 6mA DC protection (EN 62955) 30mA AC |
| Standby Power ³ | 10 Watts |
| CT Sensor Voltage | 0.333V |
| CT Sensor Specification | 0 - 120 Amps / 25mm ² maximum cable size split core |
| EVOFLEK Charging Cable ⁴ | 4mm ² Live Conductors / 32 A max current. High Performance ultra-flexible cable |
| Installation | |
| Mounting | Flush mounting location using 4x fixing points |
| Cable Entry | Rear and Bottom entry, hole cutting size between 20-25mm, molded guide provided at both rear and bottom entry |
| Supply terminal capacity | 4mm ² - 10mm ² |
| Max Voltage drop | ≤ 3% voltage drop allowance on supply cable (Dependant on length) |

| | |
|---------------------------------|--|
| Dimensions Unboxed | 286 x 172 x 110 mm |
| Mounting Height | Installed between 0.75m - 1.2m from ground level |
| CT Sensor Cable | Maximum extended length 30 metres unshielded CAT5/6 OR 50 metres shielded CAT6 data cable Any shielding to be suitably earthed |
| Recommended Upstream Protection | 40A RCBO (BSO EN 61009) or Type A RCD / RCCB (BSO EN 61008) + 40A MCB (BSO EN 60898) - B curve |
| Installed Weight | 3.4 kg - 5.2kg |
| Device Connection | |
| Internet Connection | Wi-Fi - 802.11 b/g/n support, 802.11 n (2.4 GHz), up to 150 Mbps |
| Bluetooth | Bluetooth BLE 5 (set-up only) |
| Device Support | Apple iOs mobile device / Android mobile devices |
| EVSE Regulations | Compliant with The Electric Vehicles (Smart Charge Points) regulations 2021 |

1. The mounting wall must be capable of supporting at least four times the weight of unit (44kg) and must be fire resistant

2. The mounting hardware (screws, wall plugs etc) must be selected to be appropriate for the specific structure of the mounting wall

3. The cable used must be approved to a local national regulations and standards

4. The upstream protection must be approved to local national regulations and standards. The disconnection devices, isolators, etc. must be nearby and easily accessible at all times

**DANGER**

Danger to life due to electrical voltage! Injuries due to electric shock and/or burns, possibly resulting in death, are possible.

During all work, make sure at all times that power to the system is switched off and secured so it cannot inadvertently be switched on.

- Before commissioning the device, check that all screw and terminal connections are tight.
- The termination panel covers must never be left open without supervision. Fit the termination panel cover when you leave the charge point.
- Do not make any unauthorised changes or modifications to the charge point
- Repair work to the charge point may only be completed by the manufacturer or a trained expert.
- Do not remove any identifiers such as safety symbols, warning instructions, rating plates, labels or cable markings.
- Ensure that the charging cable is not mechanically damaged (kinked, jammed or run over) and that the contact area does not come into contact with heat sources, dirt or water.

**WARNING**

Safety notice:

- Switch off on all poles and from all sources.
- Secure to prevent it being switched on again.
- Verify isolation from the supply.
- Earth and short-circuit.
- Cover neighbouring live parts and cordon off danger areas.

**CAUTION**

Ensure that the charge point is not damaged by incorrect handling (housing cover, internal parts, etc.)

On outdoor installations, do not open the termination panel cover in damp conditions.

- Do not tighten the securing screws with force.
- The installation area must be completely flat, do not bend the housing.
- Electronic components may be damaged if handled. Before handling modules, perform an electrically discharge process by touching a metallic earthed object.

Failure to follow the safety information may result in a danger of death, injury and damage to the device. The device manufacturer cannot accept any liability for claims resulting from this.

We're here to help

Send us an email



helpdesk@andersen-ev.com

Call us

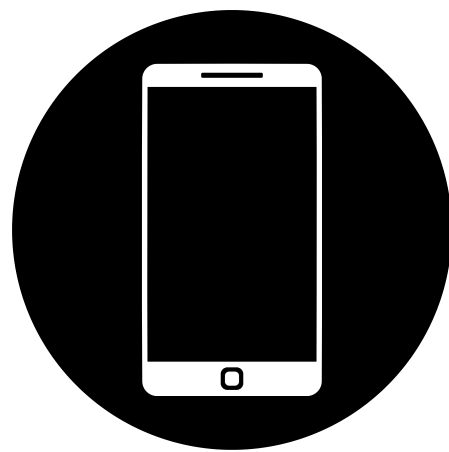

Mon-Fri 08:00 - 19:00

Sat 09:00 - 14:00

+44 (0) 1234 916125

www.andersen-ev.com