

**HYPERVOLT**

**Home 3.0**

# **Operation & Installation**

**Manual**

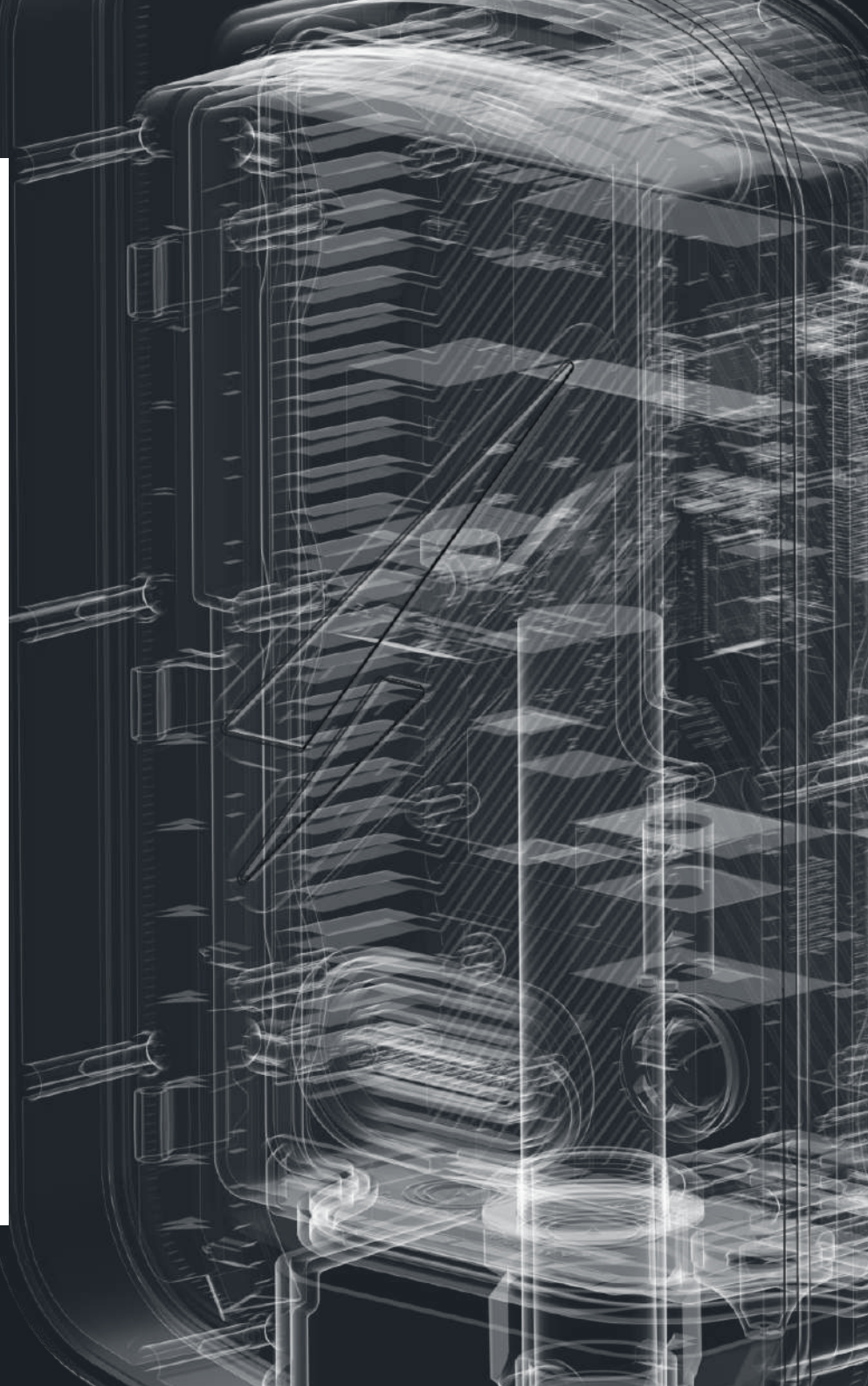

- Introduction** ..... 1
- Safety Notice** ..... 2
- Getting to Know Your Hypervolt**
  - Product Overview ..... 3
  - Technical Specification ..... 4
- Need more assistance?** ..... 5
- Installation**
  - Getting Started ..... 6
  - Enclosure Parts ..... 7
  - Mounting the Charger ..... 8-9
  - Accessing the Connections ..... 10
  - Wiring and Cabling ..... 11-12
  - Mains CT Connection ..... 13
  - Connecting the LED Plate ..... 14
  - Fitting the Front Enclosure ..... 15

- Installation**
  - Monitoring and Protection Devices ..... 16
  - Automated Load Management (ALM) ..... 17
  - Maximum Operating Current ..... 18
- Using your Charger**
  - LED Statuses ..... 19
  - Setting Up the App ..... 20-21
  - App Basics ..... 22
  - App Settings ..... 23
  - Charging Modes ..... 24
  - Hypervolt Dashboard ..... 25
  - Connecting online via Hotspot ..... 26
  - Regulations and Security ..... 27
- Support**
  - Troubleshooting Guide ..... 28-29

## Thank you for choosing Hypervolt!

---

Our team know you will be pleased by the ease of install and amazing functionality of your new Home 3.0 Smart EV Charger.

Hypervolt aims to provide customers with state-of-the-art equipment embracing industry leading smart features backed up by excellent customer service.

The Hypervolt Home includes advanced built in automatic monitoring systems to ensure your safety while in use.

This guide will provide instructions on how to correctly install and operate your new charger; by reading this guide it will ensure you or if you are an installer, your customer receives the best experience when using the charger.

***From the Hypervolt Team***



## Safety Notice

The installer and end user must read and fully understand the safety instructions provided. Disregard of or actions contrary to the safety information and instructions contained in this document, printed on the device or by other way given may lead to one or all of the following:

- Injury or potential death of the operator, installer and any other third parties.
- Improper operation, function and damage of the charger.
- Damage to the vehicle on charge, building electrical systems and the surrounding environment.

In addition failure to adhere to any of the safety precautions, notices, advice and instructions set out in this guide or by other way given in relation to either the installation or operation of this and all other Hypervolt products will invalidate the warranty.

## Legal Notice

This document is intended to be used as a reference guide for the installation and operation of the Hypervolt Home 3.0 EV Charger. The product images shown are for illustration purposes only and may not be an exact representation of the product. Hypervolt Limited reserves the right to make changes to the specifications and processes of the product and documentation at any time and without prior notice.

The Hypervolt Home 3.0 charger has been designed, developed and manufactured to satisfy requirements, safety dispositions and norms in accordance with the directives presented in the declaration of conformity.

## Disposal

Important information for the correct disposal of the product in accordance with Directive 2012/19/EC. At the end of its useful life, the product should not be disposed of as urban waste. It must be taken to a collection centre for special and differentiated disposal or to a distributor that provides this service.



### What come in the box

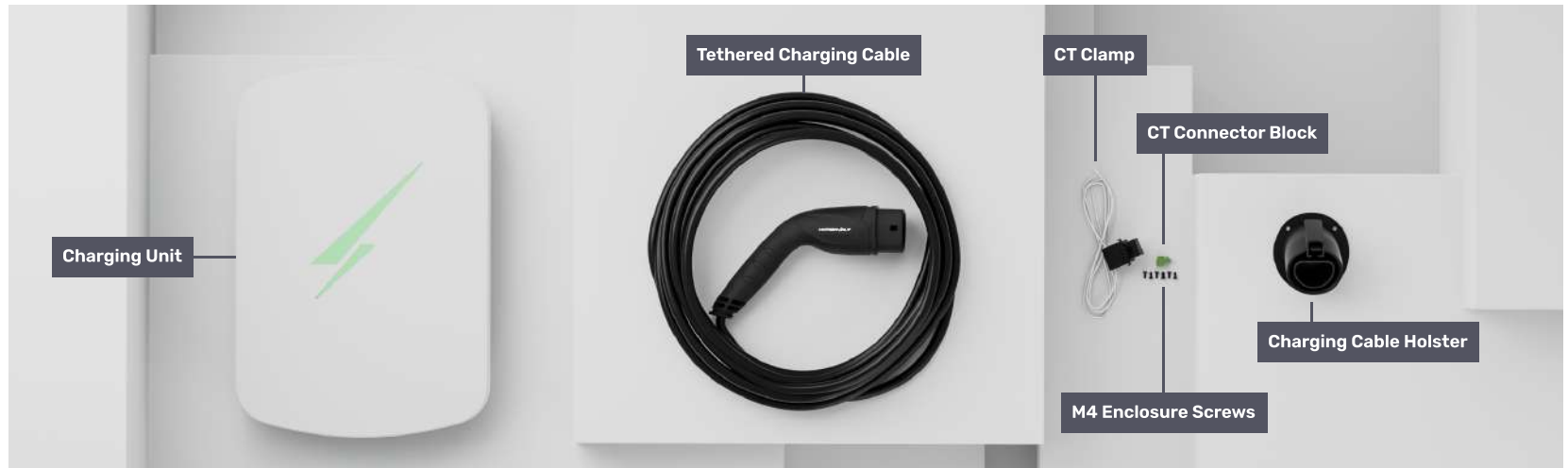

### Charging unit

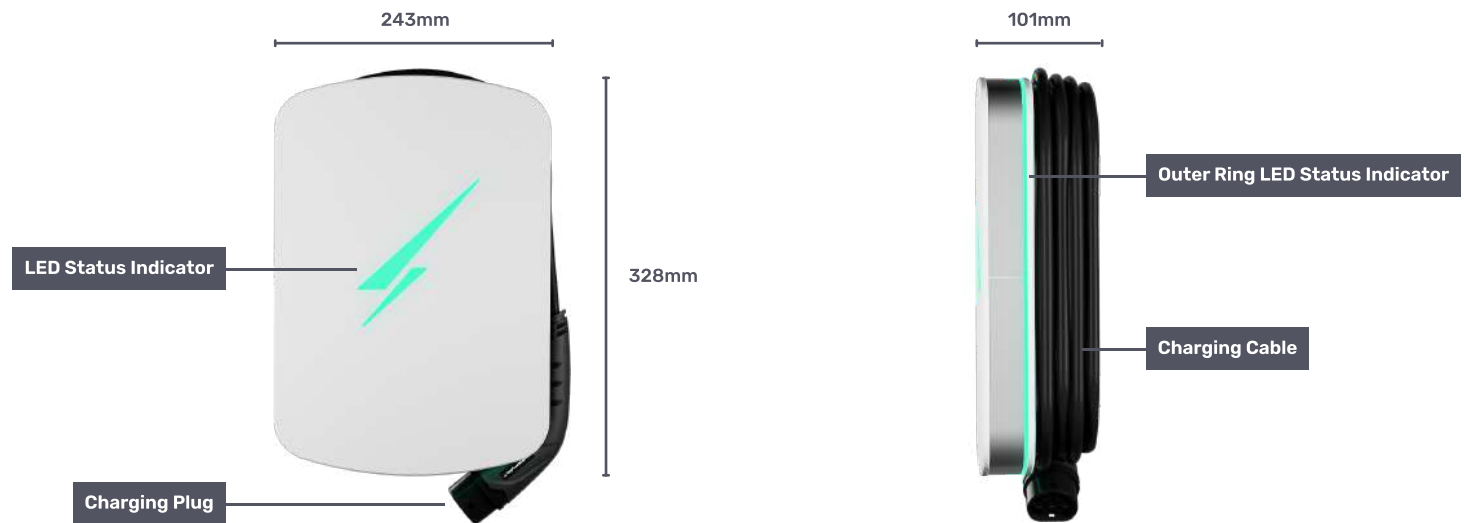

## Product Information

**Model:** Home 3.0

**Connection Capacity:** Single Phase, 7kW AC

**Charging Connector:** Tethered, IEC 62196/Type 2 OR SAE J1772/Type 1

**Tethered Cable Length (m):** 5 / 7.5 / 10

**Dimensions (mm):** 328 (H) x 243 (W) x 101(D)

**Mounting Type:** Wall/Pole mounted

**Colour:** Ultra White / Ultra Black / Space Grey

**Weight:** 5.2 Kg

**Unit Material:** PC-ABS, ABS Composite

**Charging Protocol / Mode :** Mode 3 (compliant with BS EN IEC 61851-1:2019)

## Electrical Properties

**Rated supply voltage:** 230V AC - Single Phase

**Rated power:** 7.4 kW

**Rated current of assembly:** 32A (max)

**Output supply:** AC 230V 7.4 kW Single Phase

(Note: May vary based on vehicle make and model as well as electrical installation setup)

**Mains Frequency:** 50 Hz

**Average standby power consumption:**

- **Lowest LED brightness setting:** 4.2W
- **Maximum LED brightness setting:** 8.4 W

**Energy efficiency (at full rated output):** 99%

**Rating against shock:** Class I Equipment

**Compatible earthing systems:** TN-C-S & TN-S (PEN Fault Protection) or TT

**Electromagnet Compatibility (EMC):** Classification Type B

## Connectivity

**WiFi:** Wi-Fi 802.11b/g/n @2.4 GHz

**Bluetooth:** Bluetooth LE (Version 4.2)

## Safety

**RCD Protection:** Internal 6mA DC RCD (External AC Protection Required, "A" Type Recommend.

**PEN Fault Protection:** Integrated PEN fault protection compliant with Amendment 2 of BS7671:2018.

**Overcurrent protection:** External protection required (MCB or RCBO)

**Mechanical impact protection:** IK08

## Standards and Compliance

**EV Charging Compliance |** EN 61851-1:2019, BS 7671:2018 + A1:2020

**RoHS |** 2011/65/EU

**Safety Compliance |** 2014/53/EU Radio Equipment Directive 3.1(a) - EN IEC 61851-1:2019 / EN 62196-1:2014 / IEC TS 61439-7:2014

**EMC Compliance |** 2014/53/EU Radio Equipment Directive 3.1(b) - EN IEC 61851-21-2:2021, EN 55032:2015 + A1:2020 (Class B)

## Features

**Status Indication/HMI:** Multi-colour LED's around the sides and the logo on the front of the enclosure.

**Charging modes:** Boost, Eco (Solar & Grid), Super Eco (Solar Only)

**App:** Full Function Control via the app.

**ALM:** Automatic Load Management

**Other:** Lock, Plug & Charge, Schedule Charging, Factory Reset, Tamper Alerts, Selectable LED Brightness & Modes,



## Environment

**Operating Temperature:** -25 to 40 °C | **Operating Humidity:** Up to 95% RH, non-condensing | **Environmental Protection:** IP54 | **Pollution degree:** 3

**Maximum Altitude Level:** 2000m

## Need more assistance or having trouble charging your car?

### Please contact us on:

-  0333 090 3093
-  [support@hypervolt.co.uk](mailto:support@hypervolt.co.uk)
-  <https://hypervolt.co.uk/>
-  30 Churchill Pl, London E14 5RE,  
United Kingdom



*Scan Me to Register  
Your Hypervolt and  
Claim Your Warranty*

### Disclaimer

Diagram supplied are as examples and may differ or not be the full representation of the product that you have.

This document can be subject to change at anytime without notice. You can find the latest version of the manual at [support.hypervolt.co.uk](https://support.hypervolt.co.uk).

All rights reserved by Hypervolt Ltd ©

Release December 2022 / Version 3.1

## Please read before starting your install!

- Hypervolt products must be installed by suitably qualified trained electricians only.
- Above all else the Requirements for Electrical Installations as set out in BS7671 (as amended) must be followed with special attention to section 722.
- In addition to the above the guidelines given in the “Code of Practice for Electric Vehicle Charging Equipment Installation” (as amended) by the IET must also be followed.
- If you are unsure about any part of the installation of a Hypervolt product you must obtain clarification from our technical department before proceeding.
- After installation and within 48hrs the unit must be registered as having been installed. This is done by scanning the QR code on the side of the unit or online. This is to validate the warranty, failure to do so will void the warranty. Installers must do this before leaving site.

## Location of Important Components

<b>1</b> Incoming Supply Connections	<b>7</b> Derating Dip Switches	<b>12</b> Hyperconnect Cable
<b>2</b> Tethered Cable Connection	<b>8</b> Sensing Device (RCD-DD)	<b>13</b> Top Mounting Holes
<b>3</b> CP Connection	<b>9</b> LED Front Plate Connection	<b>14</b> Bottom Mounting Holes
<b>4</b> CT Connection (ALM/Solar)	<b>10</b> Rear Entry Cutout	
<b>5</b> RJ45 Connection	<b>10A</b> Additional Cable Entry Cutout	
<b>6</b> ALM Adjustment Dial	<b>11</b> Main Brain	

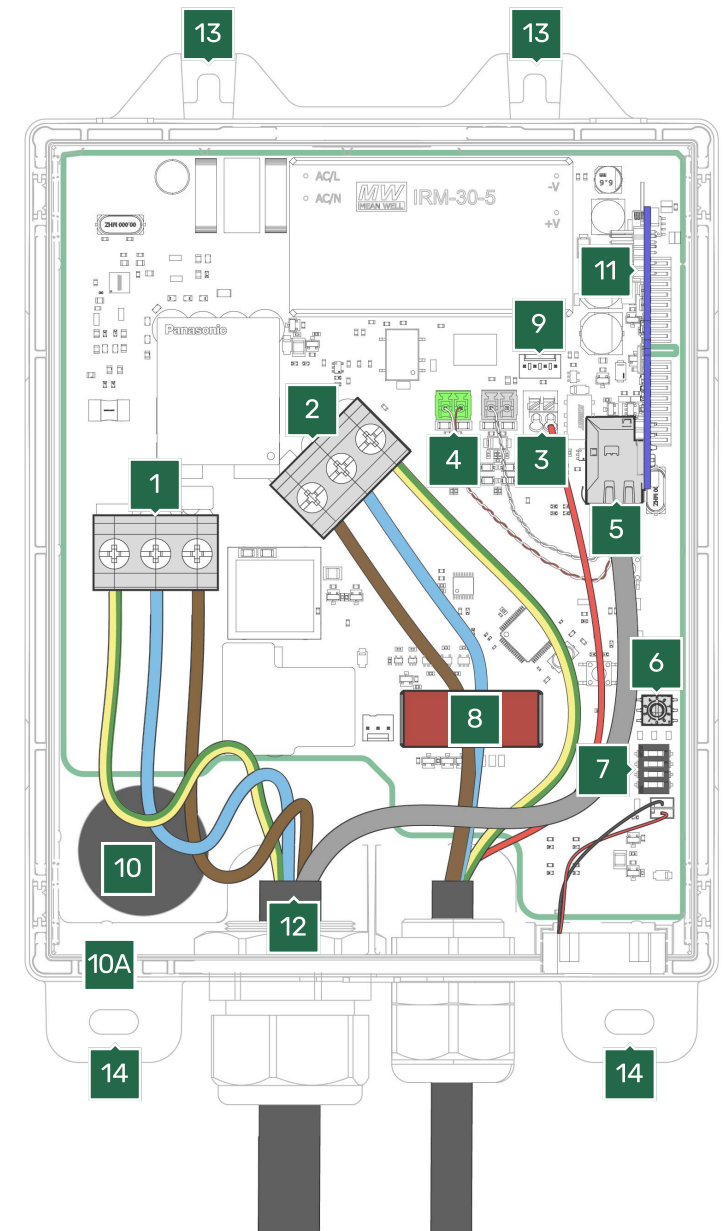

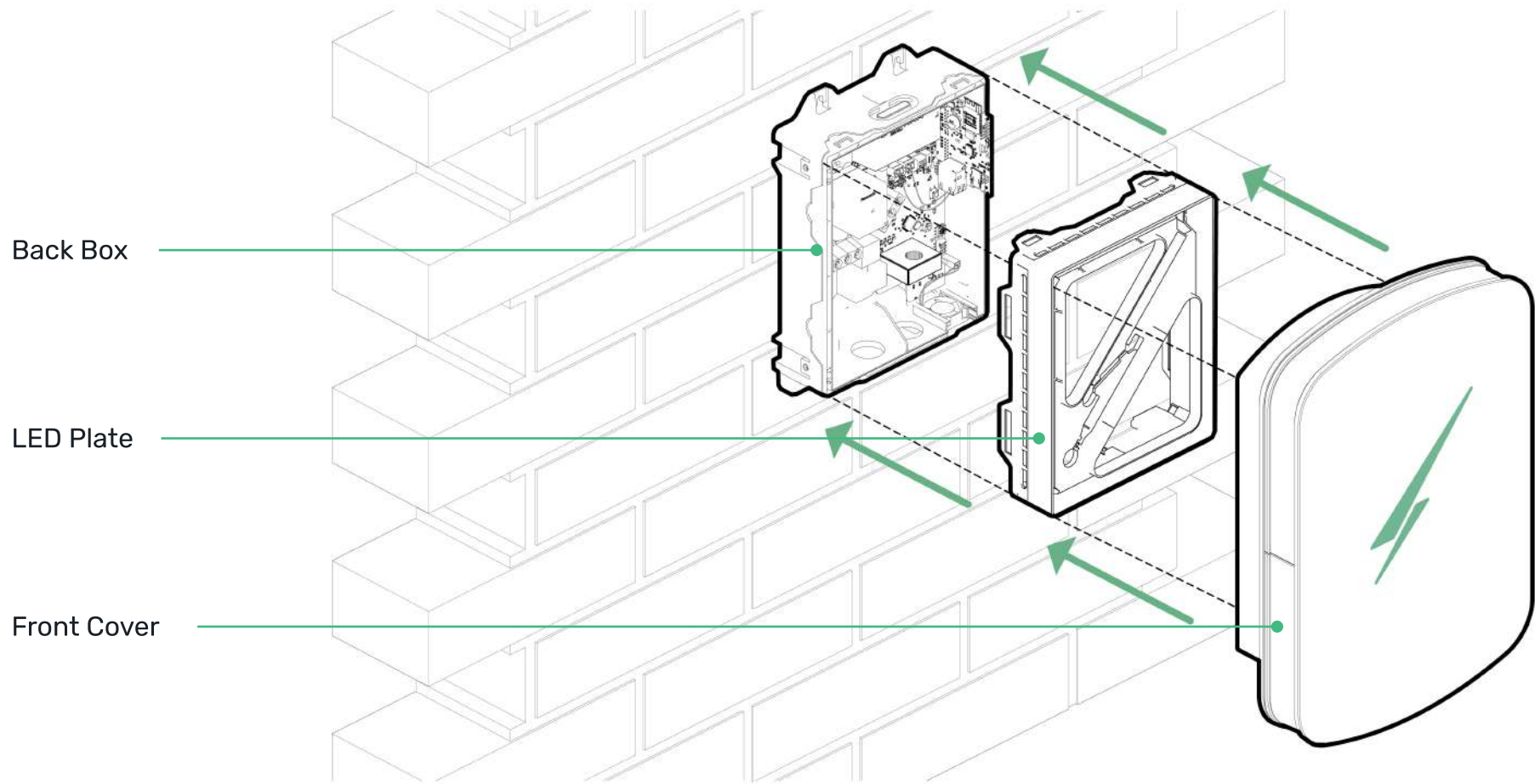

## Step 1

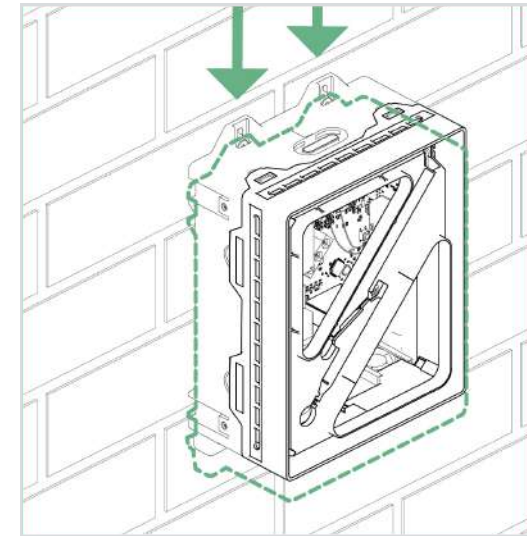
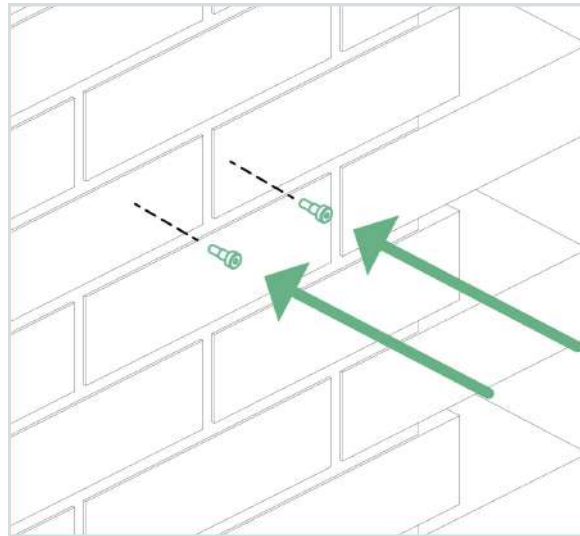
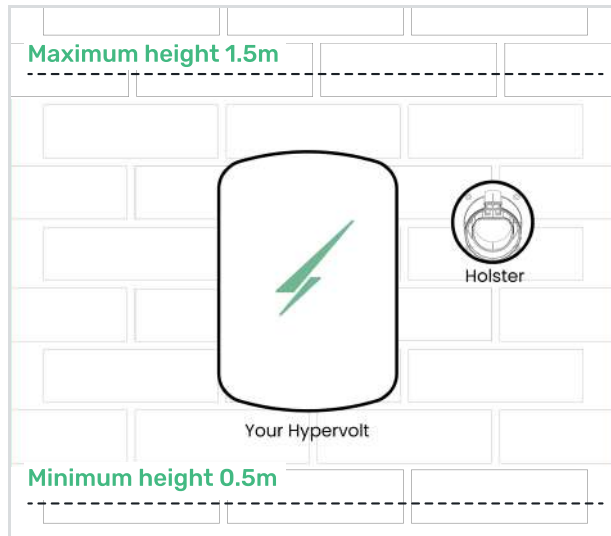

- Remove the drill template and lift the Hypervolt out of the box. Separate the front cover putting it safely to one side. Leave the LED Plate attached.
- Find a clean flat surface protected from extremes of weather if possible (Discolouration of the enclosure may happen if exposed to strong UV light for extended periods). Use the cardboard drilling template supplied with your Hypervolt to mark out the mounting holes for the back box (B). A metal template is available.
- Your Hypervolt unit and accompanying holster should be fixed between 0.5m and 1.5m above the ground. See picture for recommended holster mounting position.
- Drill out all 4 fixing holes and fit the top 2 screws (13) leaving them  $\approx 10$ mm out. For brick the recommended would be to use a 5.5mm SDS drill, Red plugs & 4x40mm screws. Hang the Hypervolt on to the top two screws.

## Step 2

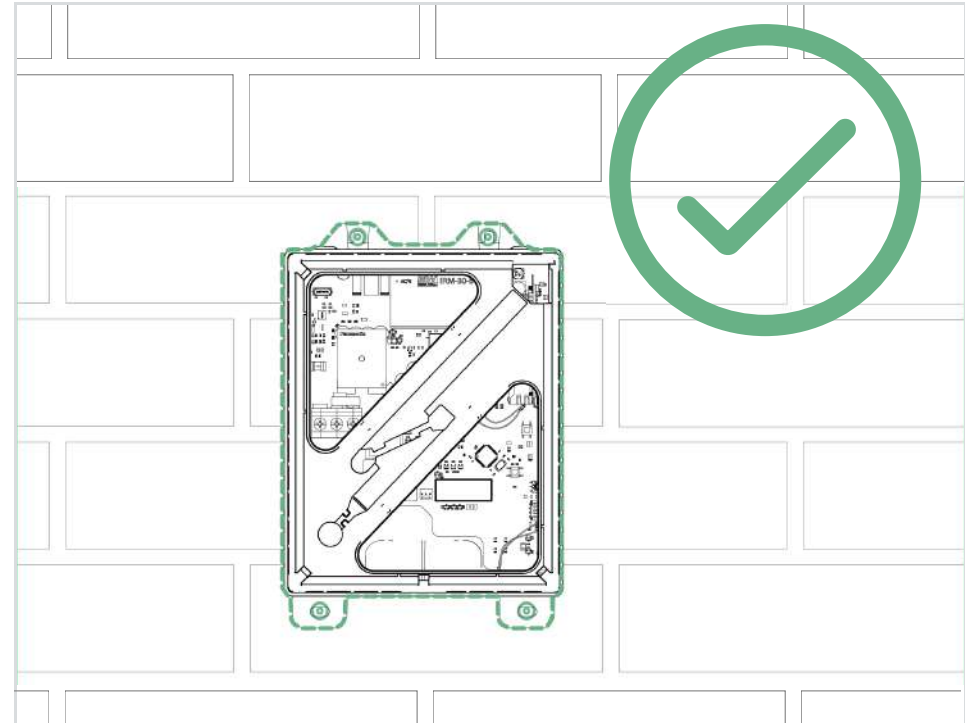
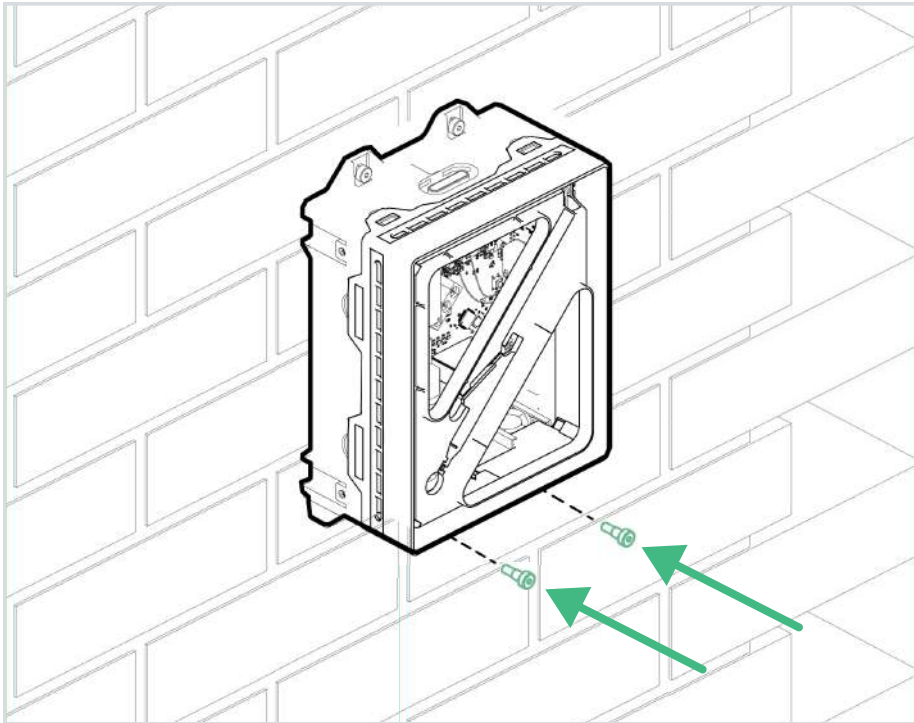

- Insert the bottom 2 screws (14) then tighten all 4 up pinching the unit up to the wall (do not over tighten or distort the back box).
- Make sure the unit is level and adjust if required.

### Step 3

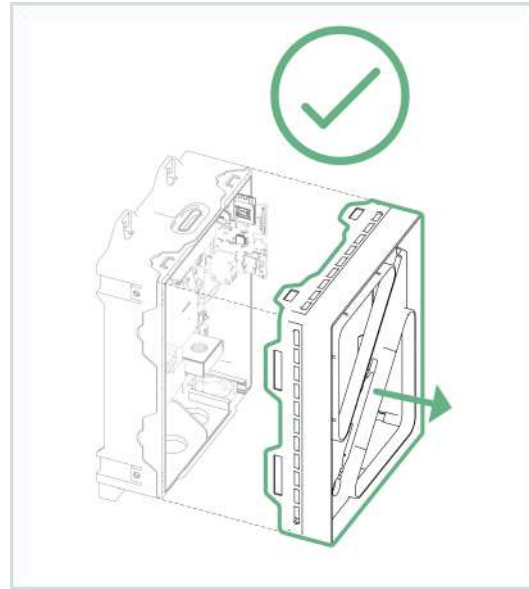
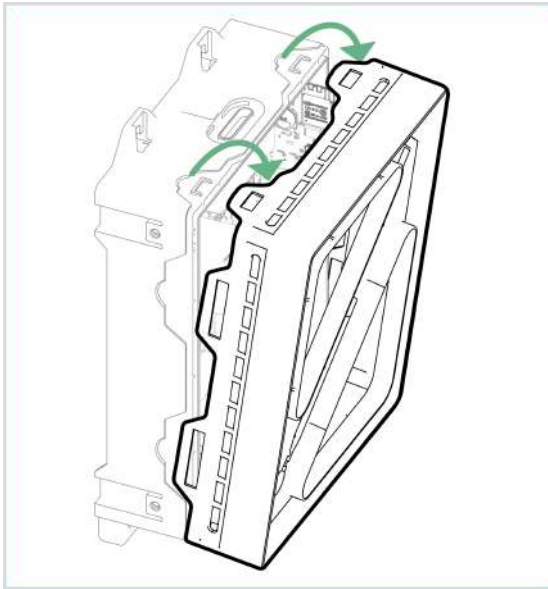

- The Hypervolt has an LED plate (B) which should be removed to access the connections and then replaced before the front cover (C) is fitted.
- To remove simply pull up on the top two tabs up and unhook the plate.
- Separate the white square cable joint behind. The unit will be shipped with this connector already disconnected however still take care on first removal just in case.
- Put the LED Plate safely to one side until you refit it.

## Wiring and Cabling

Be sure the method you use to supply electricity to the Hypervolt is compliant with The BS7671 Wiring Regulations, particular attention should be given to section 722. Remember external RCD's must be as a minimum Type "A", individual and double pole (Including RCBO's). SPD's should be fitted with consideration given to whether a type 1 or type 2 device would be more suitable

**The Hypervolt requires two types of connections;** one for supplying electricity and one for sending CT information (Load Management, Solar Input etc.). A third ethernet (hardwire) is sometimes required if the primary Wi-Fi connection is not available or too weak. Hypervolt can supply HyperConnect cable (12) which can be used to do all three connections in one neat, easier and cheaper solution. We highly recommend the use of HyperConnect cable. We do not recommend the use of NYY-J cables as these can put additional pressure on the terminal blocks.

Select the size of your incoming cable depending on your protective device rating (see next page), installation method and voltage drop. If HyperConnect cable is not being used a Cat5 cable can be used for the second connection. Cables should in general come in via the bottom gland positions however a single rear entry is available (10) which can be drilled out using a hole-saw (25mm max.). A second hole can be made for Band 1 cables (10A). All holes should be suitably sealed to prevent water ingress. The warranty is voided if the IP rating of the unit is not maintained or installations are not compliant with BS7671.

## Step 4 (At the Hypervolt)

- Connect the electrical supply cable to the terminals (1) and tighten to 2Nm. We recommend using ferrules on stranded cables. Do not use powered screwdrivers on the terminals.
- Tighten the CTS Gland provided to hold the incoming cable in place. If you are using an SWA cable then the CTS gland should be replaced for an SWA Gland (Not Provided).

## Step 5 (At the Hypervolt)

- Connect the CT clamp supplied to the green CT plug (4), you can use a Cat5 (brown or blue pair) cable to extend the connection but always end up with the white wire in the left of the plug and the black wire in the right (as per colour coding). Use the left plug socket only. Right plug socket for future secondary monitoring.
- If you need hardwired internet you can use the remaining Orange and Green pairs terminated using the T-568B colours in an RJ45 plug which can then be inserted in the RJ45 socket (5).

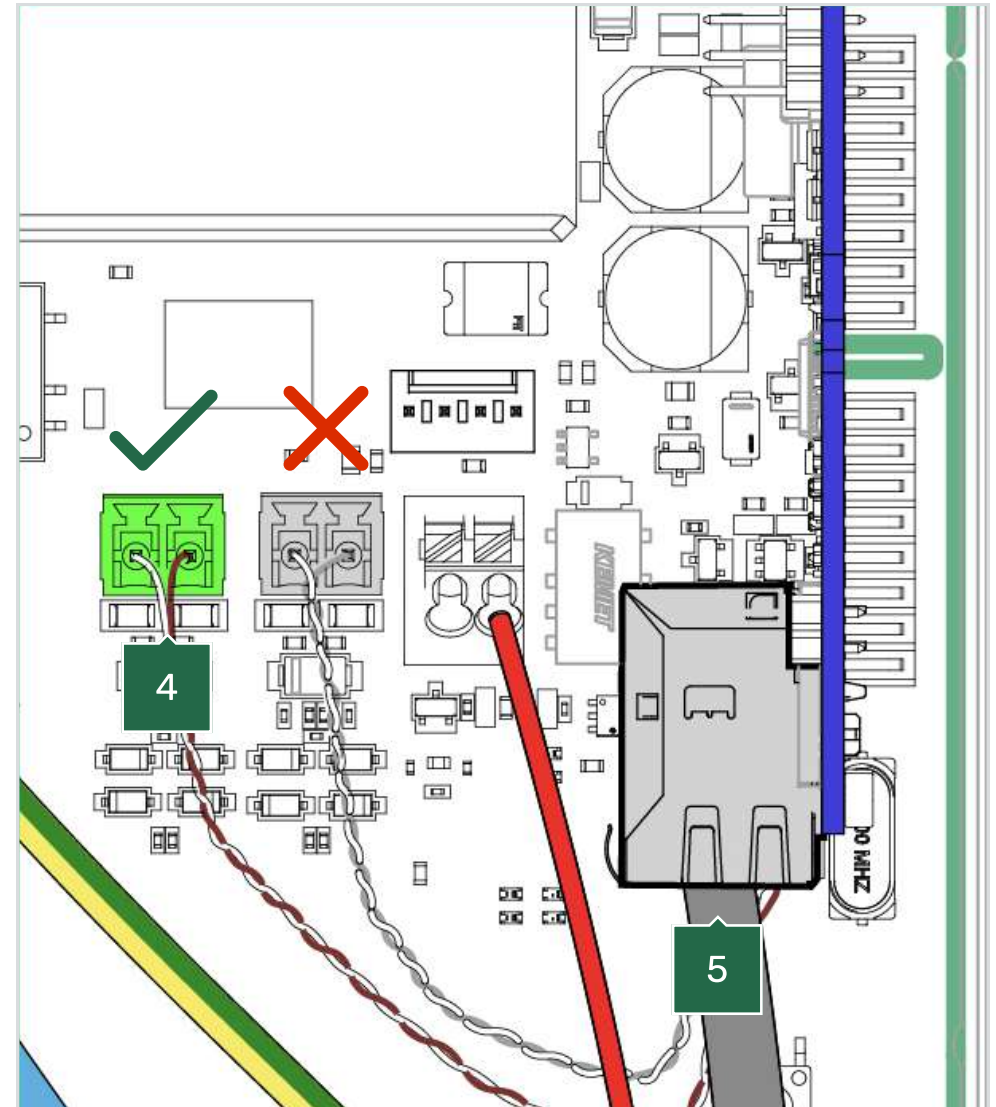

## Step 6 (At the Consumer Unit)

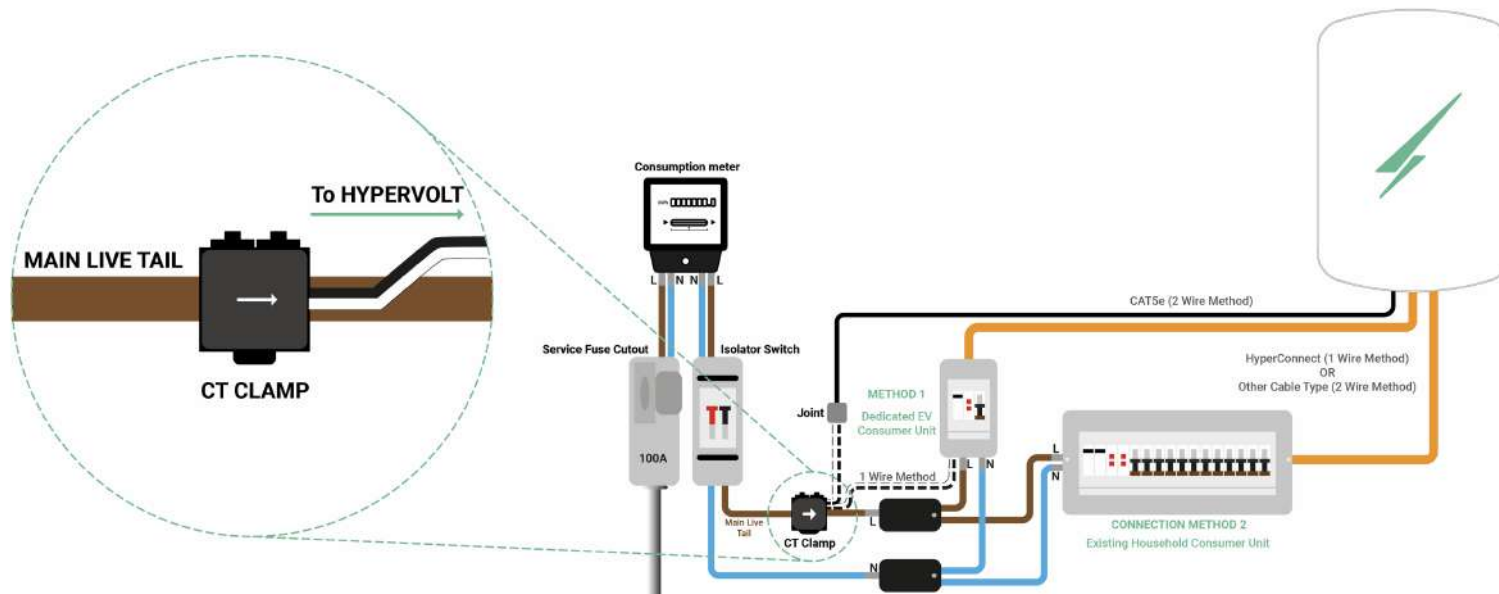

Connect the supply cable. We recommend using **method 1** below as this is the easiest way to be compliant.

### Connection Method 1:

A separate consumer unit spurred into the existing meter tails is installed just for the use of the Hypervolt unit. HyperConnect (1 Wire Method Orange cable only) is run from the Hypervolt unit and a joint made within the consumer unit to the CT Clamp. If you are not using HyperConnect then run a separate supply cable and separate Cat5 cable for the CT (2 wire method Orange & Black Cables) these cables must not be run directly alongside each other.

### Connection Method 2:

This is the same as above apart from the supply is taken from an existing consumer unit. Both wiring methods can still be used.

### For Both Methods

A suitably sized overcurrent protective device must be installed to protect the Hypervolt circuit. The Hypervolt takes a maximum load just below 32A. Consideration should be given to if a 32A or 40A device is used based upon the operating environment. A 32A device may run too warm and trip out prematurely over a long charging period especially if it is between other loaded devices. In all cases the Hypervolt must also be protected by an external RCD device (Type AC devices must not be used).

## Step 7

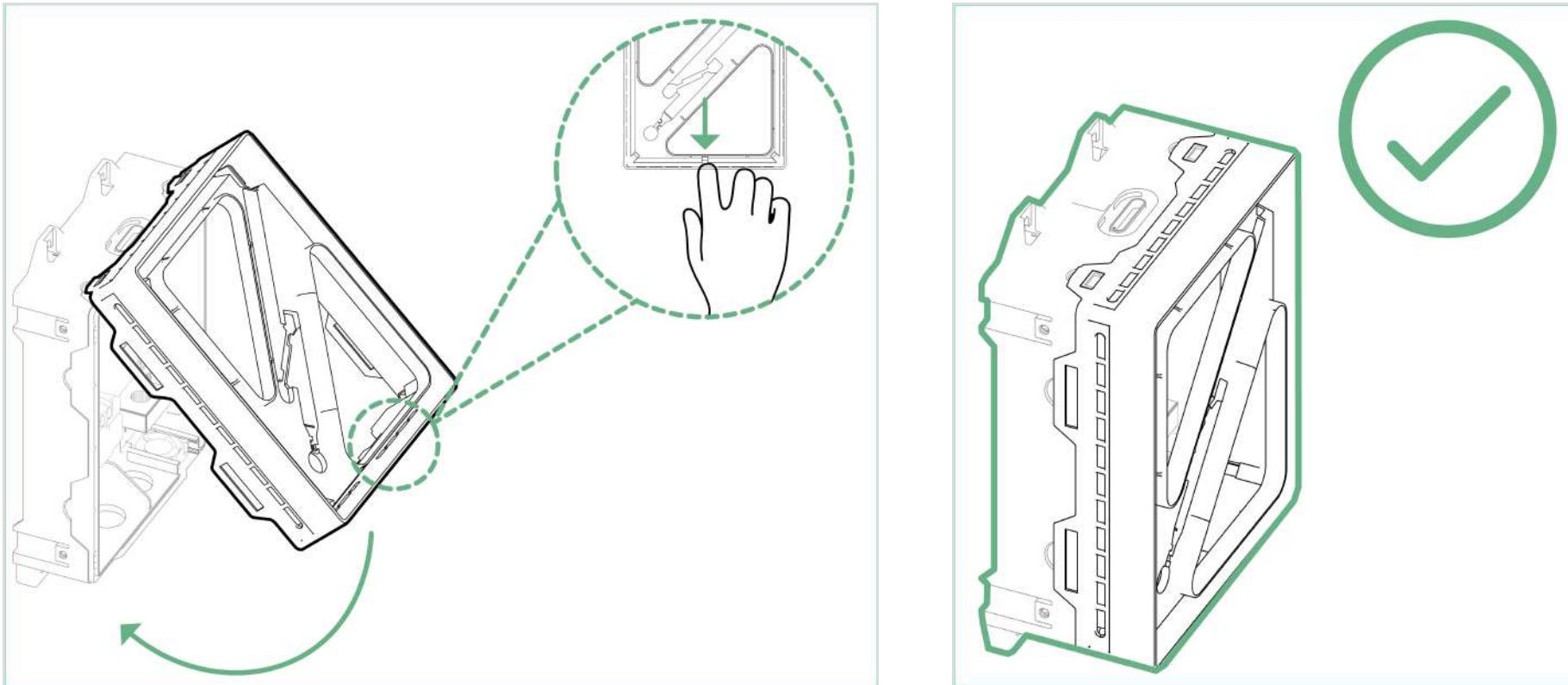

Once you have finished wiring your Hypervolt charger, you will need to re-fit the LED plate (B). First click together the white square cable joint. Put the top two tabs of part (B) over their locators on the top side of the back box (A). Now pull down on the middle bottom edge of part (B) and click the bottom into place. Take care not to trap any cabling between parts A & B. Run your hands all around the edges of the back box and LED Plate to confirm all the tabs are flat and square.

## Step 8

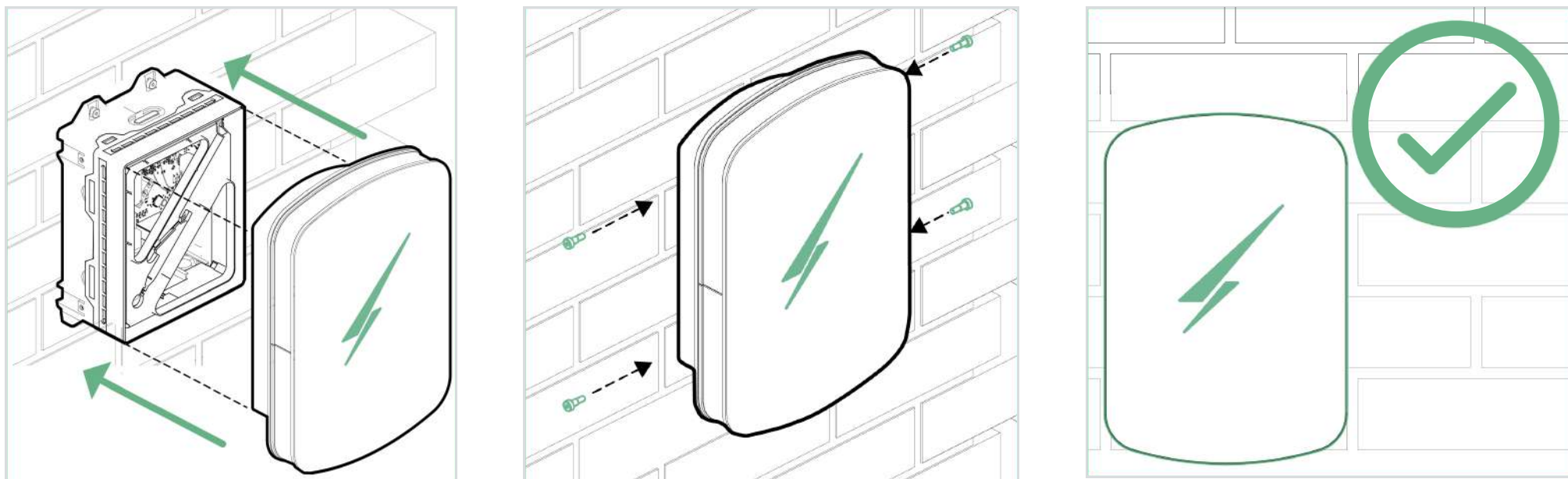

Lastly slide the front cover (C) over parts A & B and secure using the four M4 screws supplied. A small amount of pressure will be required on the front to compress the seal and line the holes up. Please take care not to cross thread the screws which only need to be hand tight, never use powered screwdrivers.

## CT (Current Transformer)

For general use a single CT clamp must be fitted at the service origin to measure the main load on the property and discover any solar export.

The CT clamp provided should go around the main incoming Live (Brown or Red) meter tail with the arrow pointing in the normal direction of current flow (Please refer to the picture on page 11).

**Note:** The CT clamp wiring can be extended up to 50m using Cat5e cable or 100m using HyperConnect cable.

---

## RCD (Residual Current Device)

An RCD is a safety device used to ensure that the charger stops supplying electricity in the event that there is an electrical fault to earth.

The Hypervolt has built-in 6mA DC protection but no built-in AC protection, it must therefore be connected to an individual "A" Type Double Pole RCD or RCBO not exceeding 30mA; complying with IEC61008-1 / IEC61009-1 / IEC60947-2 / IEC62423.

---

## PEN Fault Protection

Hypervolt chargers have built-in PEN fault protection which means they can be connected to a PME (TN-C-S) incoming service which shares Neutral & Earth in the same conductor. There is no requirement to install an additional earth rod. In the event that the Protective Earth and Neutral (PEN) conductor becomes damaged/disconnected the Hypervolt PEN Fault system will isolate all conductors to protect the user from the potential danger a PEN fault presents.

---

## Overheating Sensing

Hypervolt chargers have built-in temperature sensors; in the event where it recognises there is too much heat being generated it will reduce the current being delivered to the EV, this will ensure the charger is not damaged.

# ALM (Automatic Load Management)

Hypervolt's Automatic Load Management control is used to safely adjust the maximum charging current an EV can take to prevent the charging device being responsible for overloading the electrical service to a property.

When activated the charging current will drop to as low as 6A. Generally the ALM system will activate for short periods every so often. If the ALM is being triggered very regularly this could be a sign that the electrical service to the property is inadequate for requirements.

The dial (6) can be adjusted to set the limit at which the load manager activates. The diagram to the right shows what part of the dial is the pointer, in this case pointing to position 5.

For the ALM system to work correctly it is very important that the CT Clamp has been correctly installed (see pages 10,11 & 14)

The ALM dial is most normally set to 6 for 60A even in cases where the main fuse value is higher. The units will normally come factory set to position 6, but always check.

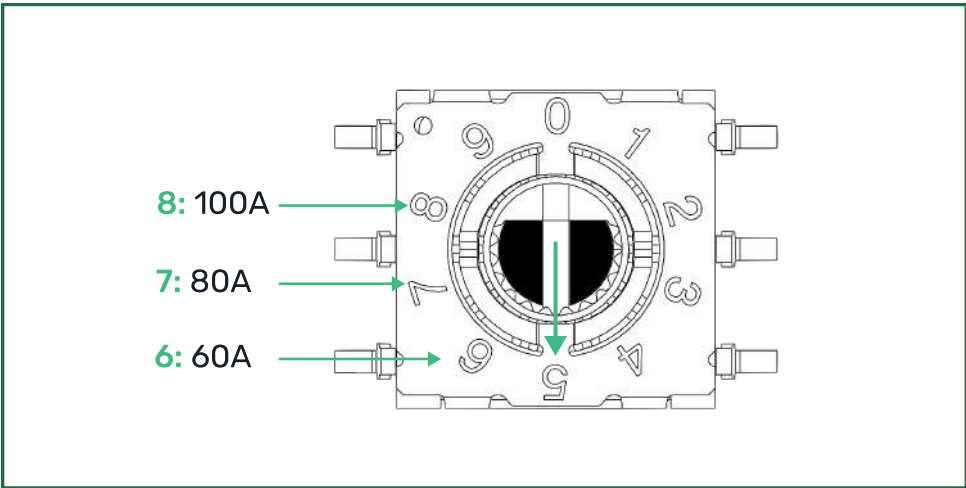
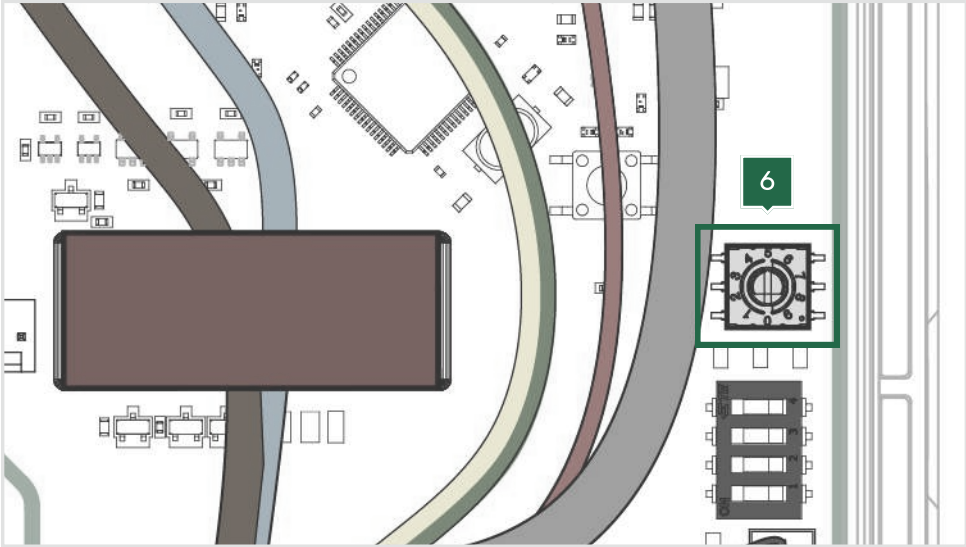

It is possible to limit the maximum current the Hypervolt Home 3.0 will operate at by permanently derating the unit using the internal dip switches. This is called a "Hard Set" as opposed to a "Soft Set" which can be done from the App.

### Setting the Maximum Operating Current (Hard Set)

- Locate the "Hard Set" dip switches (7) in the bottom left corner of the PCB.
- The dip switches are factory set to the maximum 32A (all off).
- Change the first two dip switches (1&2) to your required maximum output as per the following positions:

Reducing the maximum operating current can sometimes be requested by a DNO and should be done using the Hard Set method only.

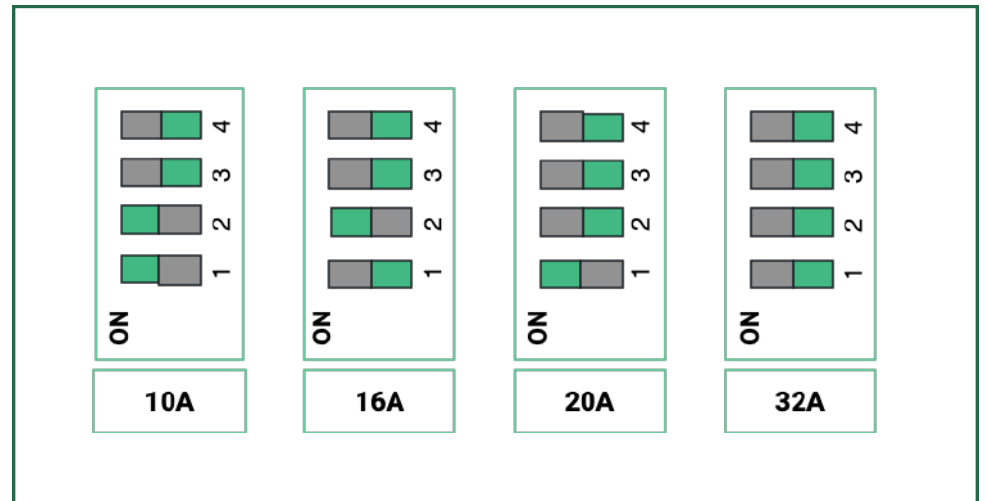
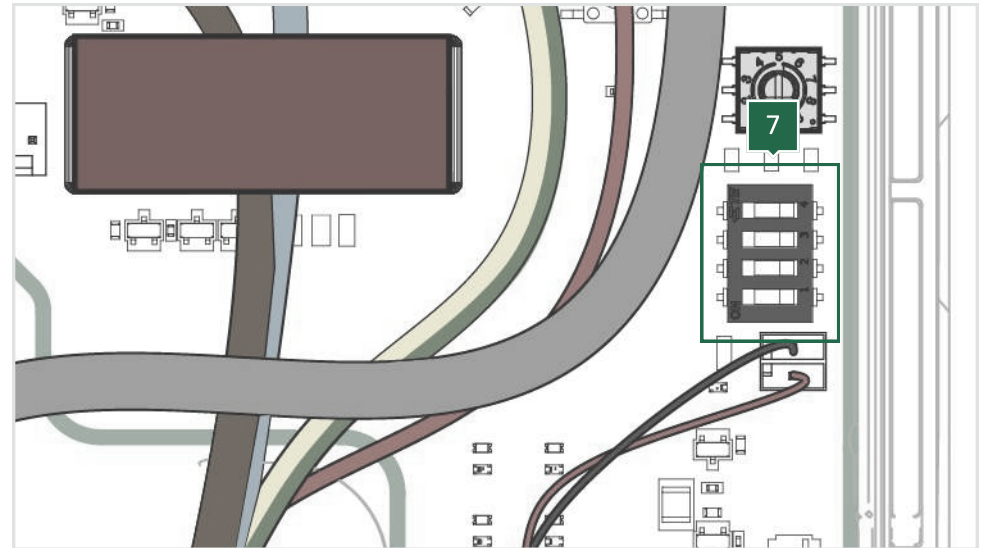

# LED Statuses



## Blue

**Solid LED:** Ready to use, no car plugged in.

**Pulsing LED:** Plugged in and waiting for car to start charge

If the Ring is Pulsing White there is no internet connection.

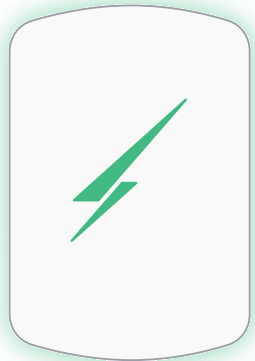

## Green

**Solid LED:** Car is charging.

The side LED's indicate the charging rate. The less on show the lower the rate.

**Flashing:** Waiting on random delay (page 25).

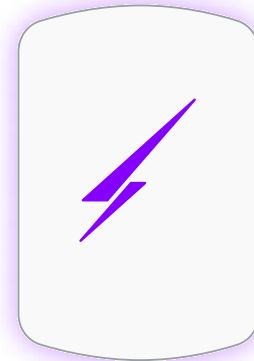

## Purple

**Solid LED:** Set to scheduled charge but no car plugged in.

**Pulsing LED:** Car plugged in, waiting to start charging accordingly to set schedule.



## Orange

**Solid LED:** Charger Locked

**Flashing LED:** A Locked charger is trying to be used.

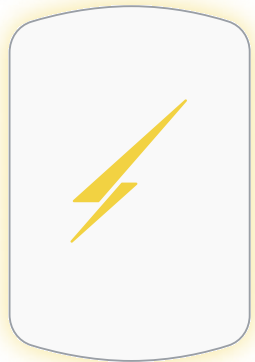

## Yellow

**Solid LED:** Charger inhibited due to lack of solar export (Super Eco Mode Only)

**Pulsing LED:** Charger stopped from app.

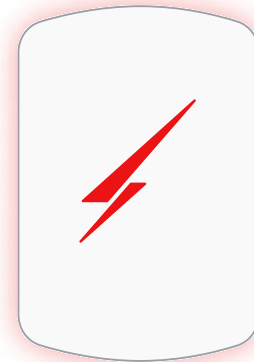

## Red

The Charger's safety system has activated. The unit is no longer charging your car.

Check status in the Hypervolt App and refer to troubleshooting on page 26.

# Hypervolt App



We recommend installing the Hypervolt App, this enables you to control and monitor the charger. The app is free and can be downloaded from either the Google Play Store (Android) or App Store (Apple). Follow the instructions below to get set up for the first time.

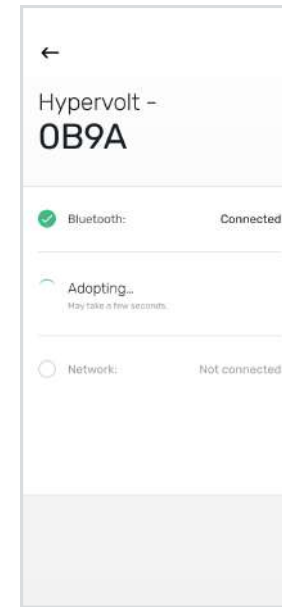
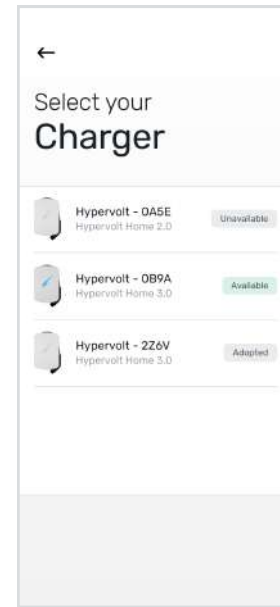
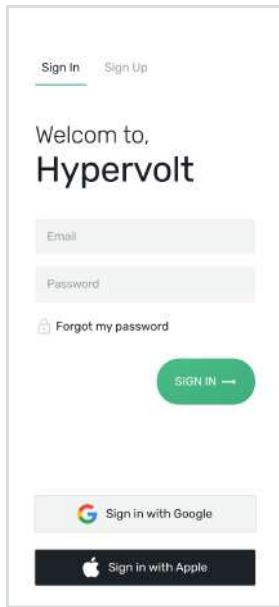
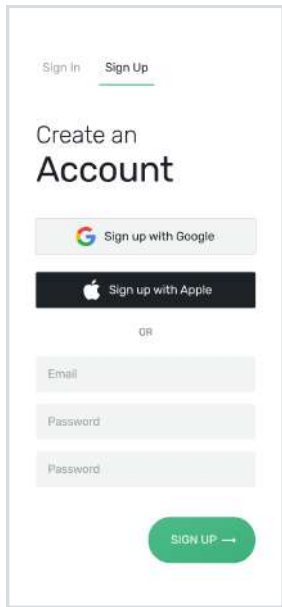

## Create an Account / Sign In

On the "Sign Up" page fill in your email address and your own unique password. Once you have done so use the 'Sign in' page to log in to your account. (If you already have a login with us you can skip creating an account).

## Let Us Begin

When you first sign in there will be no chargers adopted to your account so click start to begin.

You must be stood next to the charger to complete the next steps.

## Adopting your charger

Select the charger shown on the list as "Available". Units already assigned to an account will show as "Unavailable". Pull the list down to refresh it if unknown devices are shown.

**Note:** If your Hypervolt has been installed by a "Hypervolt Trusted Installer" they will do this part for you. You will receive an email link to adopt your charger. If you already have the App close and reopen it for the new charger to show.

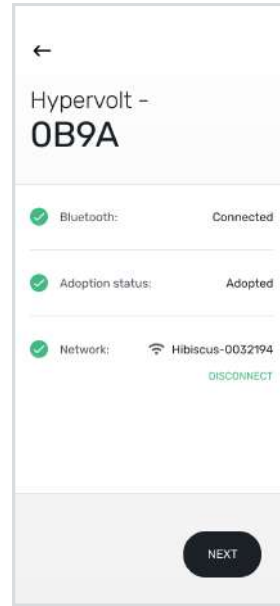
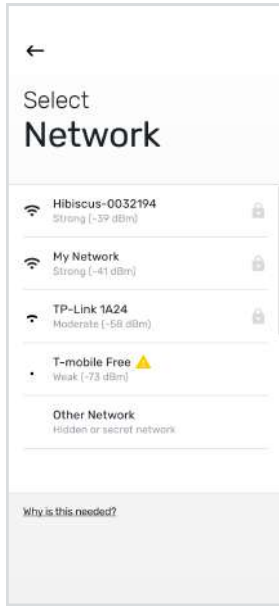
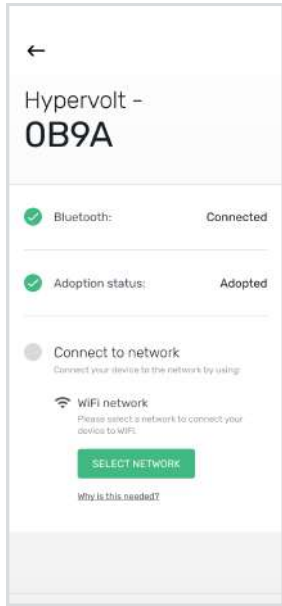

### Connect

Once the Hypervolt is adopted the next screen will display the Wi-Fi networks available in your area. Choose the Wi-Fi network you wish to connect your Hypervolt to, type in the password and hit "Connect".

Its very important that the Wi-Fi signal strength is good for a reliable connection.

**Note:** An error screen may appear should the network be unavailable or you have typed an incorrect password, if it does just tap the 'retry button'.

### Success!

Once the Wi-Fi network has been connected the LED ring around the Hypervolt will change from pulsing white to solid blue.

### Ready to Go

Now the app is connected you can control any of the functions from anywhere in the world so long as your phone has an internet connection. To confirm all is good why not try changing the LED mode or brightness ?

The information below should help you get started with the basics of using your charger with the Hypervolt app. A more in depth guide is available on our website.

**Adopted chargers**  
See here for the charger you are controlling. Pull down to switch chargers or add more.

**Charging Mode**  
The first icon displays whether the charger is on 'scheduled' or 'plug and charge' mode. Just tap on each icon to change its mode.

**Solar Charging Mode**  
Switch here between the different solar charging modes or set to boost if you don't have solar or need your car charged the quickest.

**Stop and start charging**  
By using this sliding button it toggles between charging your car and stopping charging.

**Settings**  
(see page 22 for more details)

**Charger Lock**  
By tapping the 'padlock' icon you can lock the charger to prevent unauthorised use.

**Session data**  
See real time data for the current charge session such as charging rate, cost, consumption and environmental impact.

**Energy Usage**  
View charging consumption by tapping 'energy usage' on the app.

LAST SESSION		
27kWh	0.63kg	29.8A/32A
Energy charged	CO2 saved	Charging rate

### LED Modes and LED Brightness

Here you can configure your LEDs from a selection of colour sequences / seasonal modes as well as adjust how bright the LEDs appear on the charger.

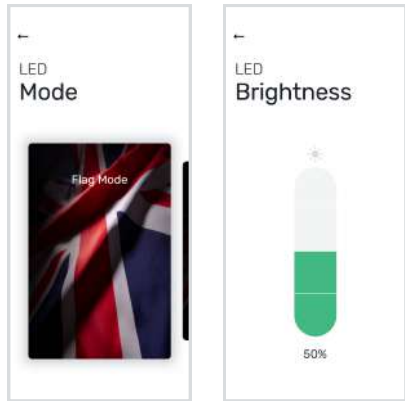

### Changing your network

If you need to adjust the Wi-fi connection your charger is linked to, can do so here.

### Setup your energy tariffs

Here you can set the prices your energy supplier charges you Day/Night to enable the app to accurately calculate the cost per charge.

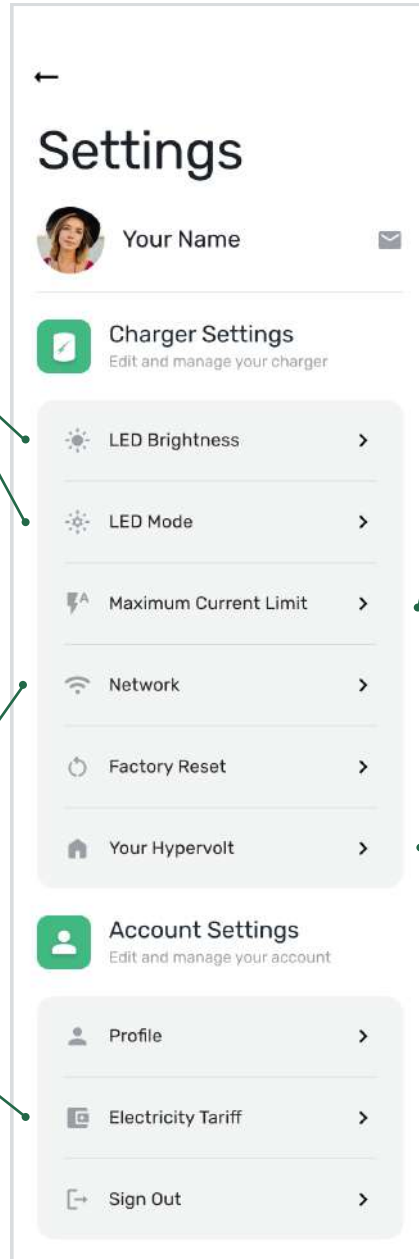

### Set Current Limit

Here you can adjust the amount of current being delivered from your charger. This is useful if you just want to trickle charge.



### Key information about your charger

Under 'Your Hypervolt' you can view unique information related to your charger, this is especially useful when you need help with support and being able to un-adopt the charger.

You can also adjust settings for 'Default Schedule' and 'Random Start'. (More information can be found on page 25 for these).

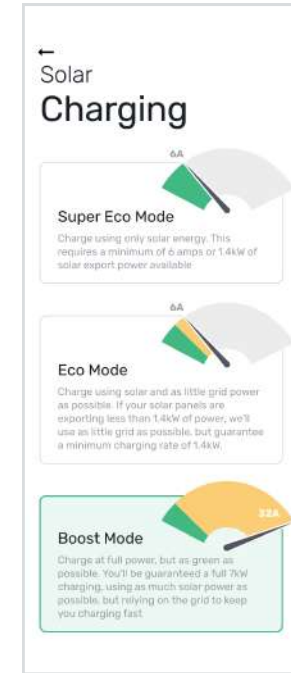
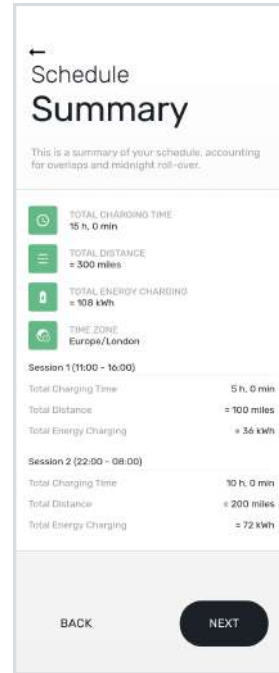
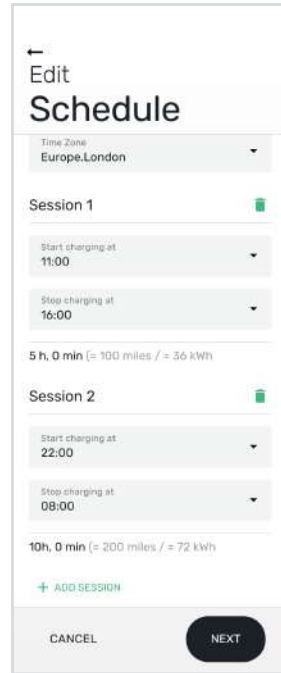
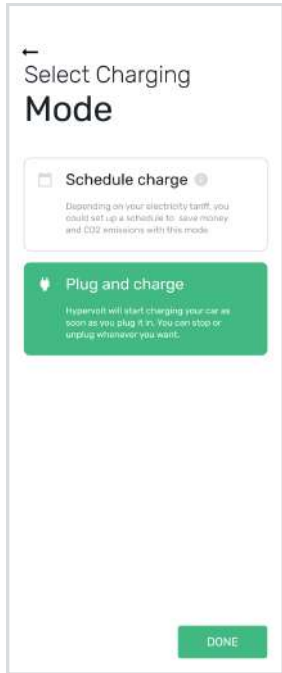

### Plug and Charge

Enables you to charge you to charge your car whenever you need to. The left of the green tab will show you which charger you are controlling. Pull the green tab down to see what chargers you have adopted to this account and switch between them or add more.

**Note:** \* **Switching Modes:** Toggle the button on the top left to switch between plug and charge and scheduling modes.

### Scheduled Charging

You can use Schedule charging mode to select when your Hypervolt charges your car maybe to match up with a cheap rate tariff.

Editing Schedules: Here you can adjust the times per session and use the 'add session' button to create multiple session should you need.

Schedule Summary: After editing your schedule, you will get a view of all the sessions as well as estimated mileage gained against the rate of charge per session.

**Note:** Your charger comes preset with a default schedule (see page 26).

### Solar Charging

By tapping the arrow below the locking icon you can switch your charger to use the following modes; Boost, Eco and Super Eco.

### What is the Hypervolt Dashboard ?

Using the Hypervolt Dashboard, you can access limited information and controls to your charger through your laptop/desktop web browser.

### Accessing the Hypervolt Dashboard

Go to [www.hypervolt.co.uk](http://www.hypervolt.co.uk) and in the top right corner click the 'Sign In' link (Please use the 'Sign Up' link to create an account with us if you do not have one already). Once you have signed in you will now be able to see the 'Profile' , by clicking on the drop down arrow you can then access via the 'My Dashboard' link.

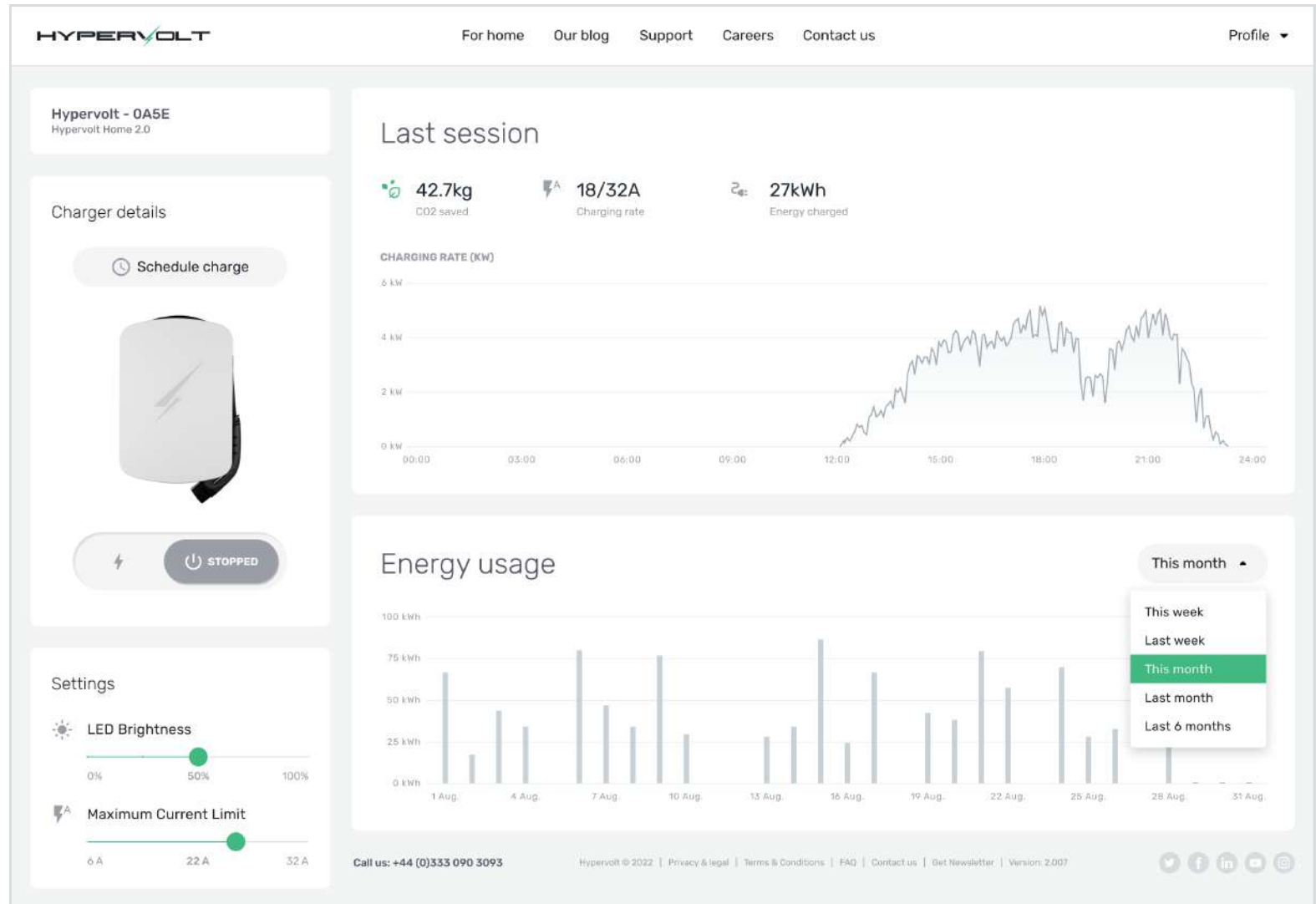

If you are having bluetooth connection issues or struggling to get the device online we have an alternative method by connecting the unit using Hotspot.

**Adjust your network settings before proceeding:** You will need to disconnect your current Wi-Fi network by temporarily turning off 'auto connect' or tap 'forget the network' in your network settings. You will also need to turn off your mobile data as well during this process. When you tap 'forget network' be sure to write you password down just in case beforehand so you can connect back again after.

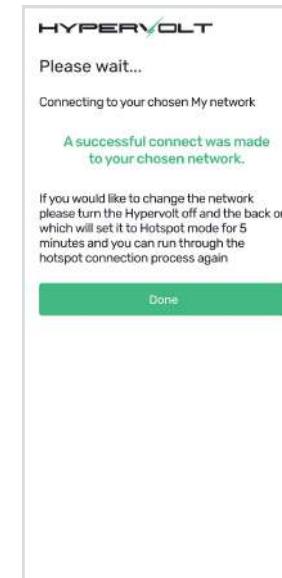
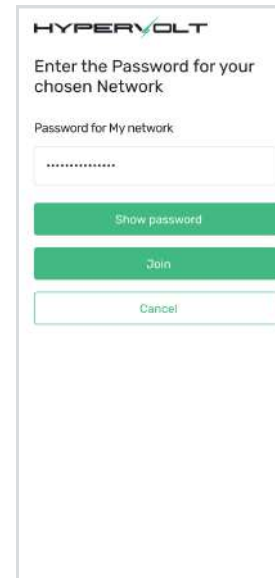
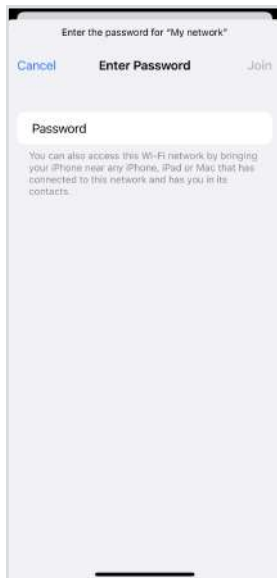

## Finding the hotspot

Go to your wifi settings and search for a new Wi-Fi network, amongst your list of connections your hotspot should appear as 'Hypervolt-xxxx'.

## Connecting to the hotspot

Next open your browser i.e. Safari or Google Chrome and type in the address bar '[hypervolt.energy](http://hypervolt.energy)'. It should display a list of available WiFi connections, select the one you need to connect to and enter your WiFi password.

**Note:** \* The RSSI (signal strength) needs to show less than -70 dBm to connect and maintain a good connection with the charger.

## Success / Confirmation

You will be presented with the confirmation page, please read through and then tap 'connect'. The ring around your Hypervolt charger will change from pulsing white to solid blue to confirm connection. You can now reconnect your phone back to your standard WiFi connection.

### What are the new regulations ?

The government commitment that all new cars & vans must be fully zero emissions by 2035 will significantly increase the demand on the electricity system. To help manage this demand "Smart Charging" of electric vehicles by "Smart Chargers" has always been encouraged and the new 2021 No 1467 Regulations just enforce some further requirements of "Smart Chargers". The Hypervolt Home series have always been smart chargers and already complied with most of the changes but here is a bit more information about what's new:

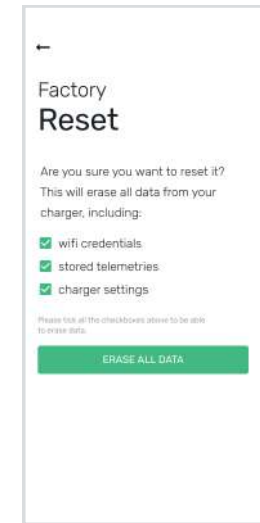
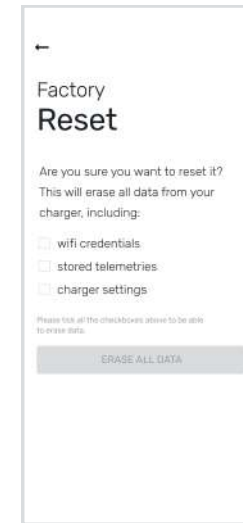
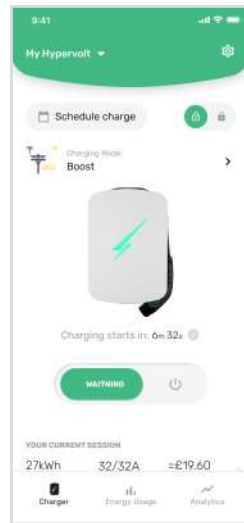

### Default Schedule

Your Hypervolt will come with a pre set off peak schedule.

You can opt out by either changing the schedule, choosing Plug & Charge or unselecting "Default Schedule" on the Your Hypervolt page.

**Note:** To Installers: Any default settings changed to enable testing of the Hypervolt Unit must be set back to the default setting upon completion of the installation. Setting - Your Hypervolt - Default Schedule and Random Start - Both Set to On.

### Random Start

Your Hypervolt will come pre set to do a random start every time a charging session starts in Boost Mode whether that be from a schedule or a straight Plug & Charge. The charge will start anytime up to 10 minutes. The delay will be shown just below the Hypervolt icon on the start page. The charging indicator will change from "Waiting" to "Charging" when the random delay is over. You can opt out of this by unselecting it on the "Your Hypervolt" page.

### How to delete your personal data from the device

Whilst Hypervolt Home 3.0 does not store personal details about yourself, it does store information about how you use your charger, wifi credentials and other information that the charger needs to support its features and maintain any settings.

You can delete any data stored on your charge point by going into your app then settings -> 'Factory' Reset.

## 1. The charger looks off and no lights are showing

This could mean that there is no power reaching your Hypervolt device. Usually as simple as a circuit breaker that is off or has tripped. Please check the circuit breaker and make sure that it is ON. Press the test button on an RCD/RCBO style circuit breaker to test that it works.

Have you checked the circuit breakers of your unit but the charger is still looks off?

It could be that you have turned the LED brightness down to 0%, check in the app (Settings - LED Brightness) and turn them back up to 100%

## 2. The charging cable does not disconnect from the vehicle

The Hypervolt Home device is unfortunately not responsible for locking the cable inside your vehicle charge port. It is the electric vehicle which must release the charging port lock in order to allow the cable to be safely disconnected.

It could be that the vehicle did not end the charging session. You must end the charging session from the vehicle before removing the charging cable. Check the vehicle user guide in order to ascertain how this is done for your particular make and model. Although each vehicle has different requirements for stopping the charging session, the charge port unlock button is usually found in the centre console, near the driver's door or on the key fob.

If you are really stuck most vehicles have an emergency release cable you can pull, consult your cars manual to locate this.

## 3. The charging session does not start

There are a few reasons why a charging session might not start:

- The vehicle is scheduled to charge at a later time.
- The vehicle is completely charged, hence it cannot charge anymore.
- The vehicle may have an error, check the vehicle for any messages.
- The charging plug is not connected properly, unplug the charging connector and re-connect.
- The charging plug may be dirty or damaged, ensure that it is in good condition.

## 4. The charging session finished earlier than expected and my car battery is not full

Please check that your vehicle does not have a maximum charge limit set which is limiting the battery charging to a level less than full. Some vehicles have this setting available to the driver in order to reduce congestion at the motorway charging services.

## 5. The charging time is greater than expected

When a vehicle's charging session is almost complete, the charging speed and input power begin to fall below the maximum available. Please check your vehicle's dashboard for an indication of the charging power and whether it is at the level you expect it to be.

## 6. Vehicle only charges at a lower power than expected

Please check the specification of your vehicle make and model and verify the maximum power figures for AC Mode 3 charging. Some vehicles have a maximum charging power of less than what the maximum a Hypervolt Home device can deliver.

If the vehicle always charges at a lower power than specified for its make and model, and has never charged at a higher power, please check whether a power limitation has been enabled during your installation (Hard Set) or if you have the current limited in the app (Soft Set).

## 7. The charger is displaying a pulsing red colour

The Hypervolt Home device has detected a problem during your charge session. Firstly try resetting the charger by turning it off then back on after 5 minutes.

If the problem persists contact Hypervolt support.