



evec
for everyone

ELECTRIC VEHICLE CHARGER INSTALLATION AND MAINTENANCE



Model: VEC01 VEC02
VEC03 VEC04

Apple



evec App
Download

Android



evec App
Download

TABLE OF CONTENTS

PRODUCT DESCRIPTION	3
GENERAL SUMMARY	3
General regulation	3
PRODUCT DESCRIPTION	4
PRODUCT DIMENSIONS	4
PRODUCT FUNCTION	5
POWER MANAGEMENT	5
PEN fault protection	5
BUTTON FUNCTIONS	5
Telecommunication	6
INSTALLATION INSTRUCTIONS	7
<u>ATTACHMENT</u>	7
<u>TOOLS/MATERIALS REQUIRED (NOT INCLUDED)</u>	8
<u>INSTALLATION LOCATION</u>	8
<u>WARNING</u>	9
<u>CONNECT ELECTRICAL WIRING</u>	9
<u>INSTALLATION</u>	10
<u>INSTALLATION OF THE CABLE HOLDER</u>	15
<u>SET THE DIP SWITCH</u>	16
<u>INSPECTION</u>	16
PRODUCT EXPLODED VIEW	17
APP INSTRUCTION	19
TROUBLESHOOTING	25
<u>INDICATOR LIGHT AND MAINTENANCE</u>	25
Q&A	31

PRODUCT DESCRIPTION

GENERAL SUMMARY

General regulation

1. Reference standard:

IEC61851 Electric vehicle conductive charging system.

IEC62196 Plugs, socket-outlets, vehicle connectors and vehicle inlets –Conductive charging of electric vehicles

BS7671:2018 Requirements for Electrical Installations

2. Electricity supply condition of the EV charger Installation

(1) Make sure that the installation location complies with current laws and regulations.

(2) Confirm that there is a suitable input voltage power supply at the installation site (consistent with the nominal power supply of the product).

(3) The charger must be electrically protected by installing externally a Miniature Circuit Breaker (MCB) and any other protection devices according to the wiring regulations at the time.

(4) If the power supply line of the EV charger is directly installed on the switch of the general household, it must be ensured that after increasing the maximum rated output current of the EV charger, the general household switch can still carry the requirements of the full load of household electricity.

If frequent trips occur:

4a. You can purchase a household load balancing current transformer, and get load balance.

4b. You can contact the electricity power company to increase the total load power;

4c. Reduce the maximum charging current.

5) The specifications of the EV charger wire and the circuit breaker are related to the rated output current actually adjusted by the charger. For details, see the form list of setting Power of the EV charger.

3. Installation condition of EV Charger

1) The charger must be installed on a secure solid surface that can support the weight of the charger;

2) There should be a certain space around the unit for installation and future maintenance. There should pre-leave more than 250mm of space on the left and right sides of the EV charger.

PRODUCT DESCRIPTION

PRODUCT DESCRIPTION

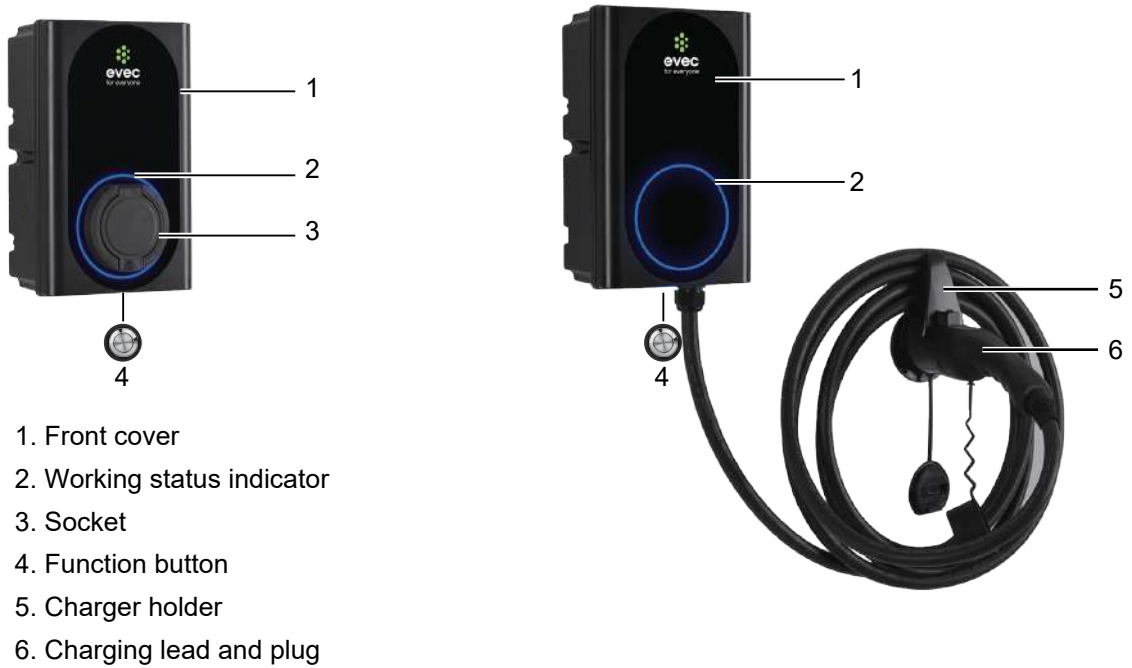

PRODUCT DIMENSIONS

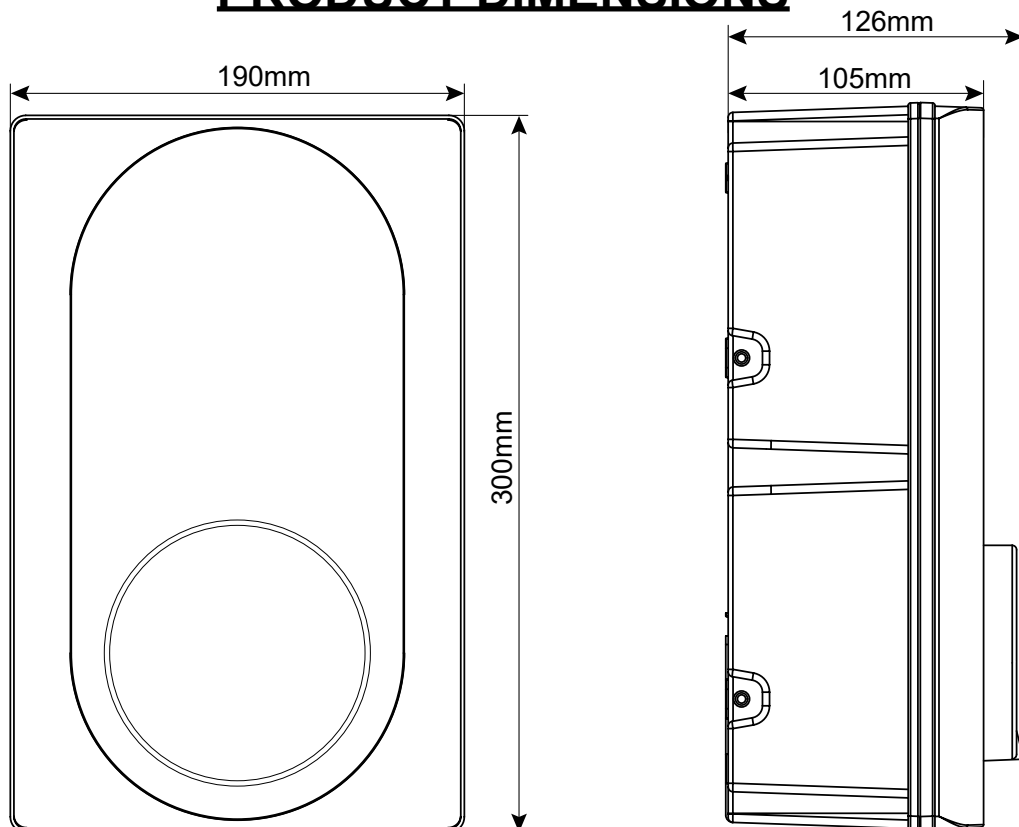

PRODUCT FUNCTION

POWER MANAGEMENT

Product with power management function can self-regulate the output current to keep the total household electricity load not exceeding the maximum incoming supply of the household current.

Note: For three phase only. If the current values of the three live wires monitored by the three-phase power are not equal, the product will calculate the minimum output current by itself, and the three output lines will be executed according to this minimum output current;

To set the maximum power after the product is connected to the WIFI, open the APP and go to settings and then Input Orders and set the total allowable current value by typing in Home then the current value. So for 50A set as **Home50**. For detailed settings, please refer to "Input Orders".

PEN fault protection

The Protective Earth and Neutral (PEN) conductor refers to part of the electricity supply cable to the property. If this conductor is damaged there is a chance that the chassis of the electric vehicle becoming become "live" and cause an electric shock. BS7671:2018 Amendment 1:2020 part 722.411.4.1 requires that extra protection is provided to prevent an electric shock – either by fitting an earth electrode or through a device which detects the fault and disconnects the supply.

The EVEC charger has RCD2 protection and will disconnect the output if it detects a problem with the PEN conductor or detects that there may be any electric current flowing through the chassis of the EV. This PEN fault protection means that there is no need to install an earth electrode with the unit.

If the unit detects a problem with the PEN conductor then the red light will start flashing two fast, two slow.

BUTTON FUNCTIONS

Function button operation instructions

Function	Operation	Status indicators	Remark
Emergency stop	During normal charging, press once	Red light flashing one fast, one slow	Disconnect from the car
Mode toggle	On standby state: 1.Under APP control mode,press 5 times continuously to enter plug and charge; 2.Under plug and charge,press 5 times continuously to switch the randomised delay off or on; Note: plug and charge : automatically starts charging after the connection is confirmed. Randomised delay:the unit operates with a delay of up to 600 seconds at each time.	Beep twice	If you want to cancel plug and charge,click schedule by APP on standby state
WIFI reset	On standby statue, press and hold for more than 10 seconds to reset the WiFi,	Beep twice	The charger will need to be re added to the APP

PRODUCT FUNCTION

Telecommunication

This product complies with the OCPP1.6J service protocol. After you set the IP and ID by the APP and the network cable is connected to the Ethernet port, the product will automatically connect to the server to enable backstage control. To set the IP and ID, please refer to the settings in the APP.

NOTE: Instructions for OCPP control setup in commercial / workplaces where a IT security system exists by a firewall

When connecting the charger to be used through OCPP the dip switch must be set and the Ethernet cable connected to the RJ45 port. For OCPP use in workplace environment where a firewall exists then the following will need to be performed by the workplace IT department for the charger to be able to be used through OCPP.

In order for the device to send and receive heart beats the firewall will require the mac address to be allowed in and out of the corporate firewall. The mac address can be found on the sticker (rating label) on the bottom of the charger.

If any security features are enabled then the device will require being added to the bypass / whitelist groups. For instance if the firewall has content filtering, DPI-SSL, intrusion prevention then the device will require being white listed through these also.

If you want to do this using IP address, then it will require the IP to be static/reserved.

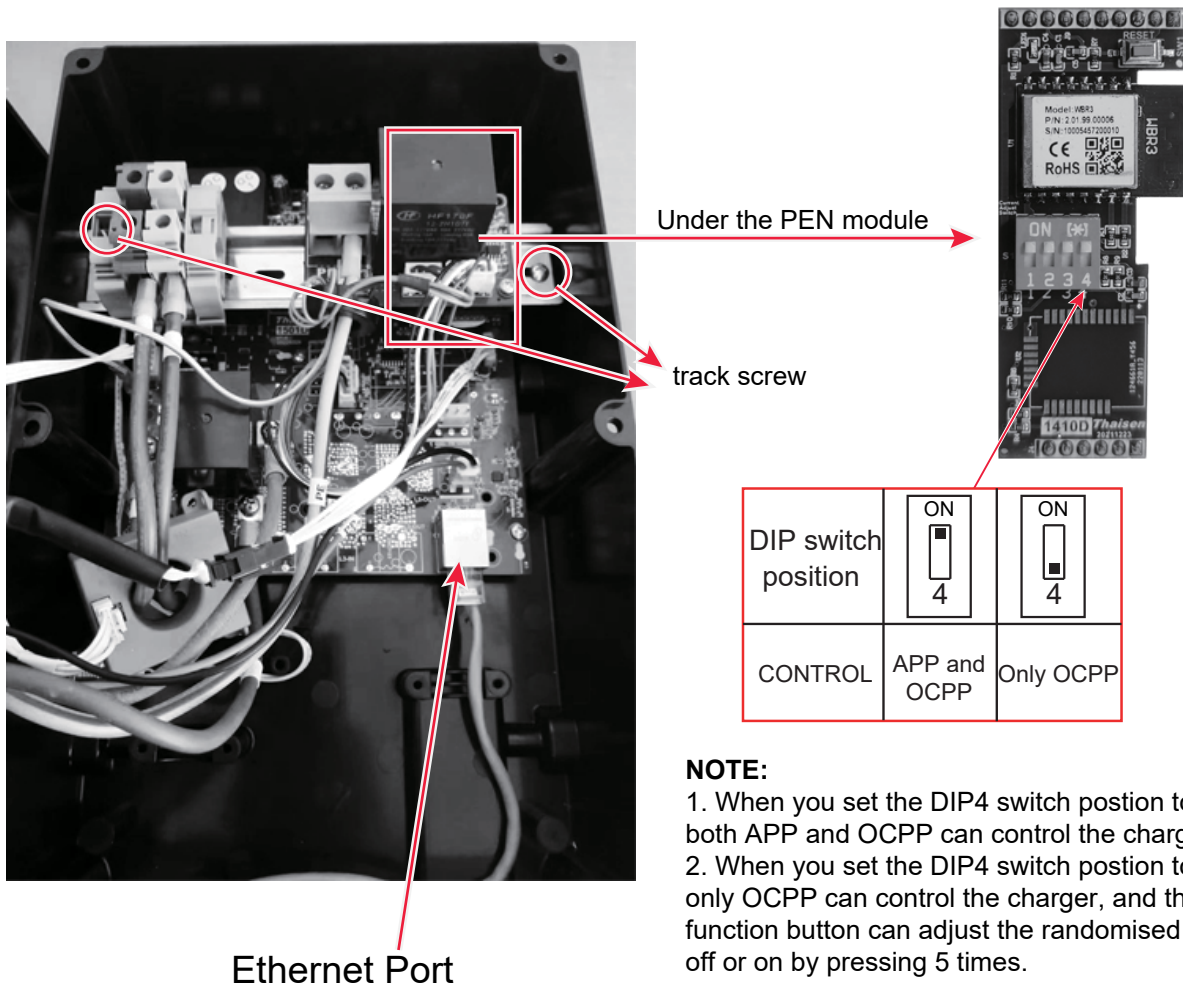

Ethernet Port

Under the PEN module

track screw

NOTE:

1. When you set the DIP4 switch position to on, both APP and OCPP can control the charger;
2. When you set the DIP4 switch position to off, only OCPP can control the charger, and the function button can adjust the randomised delay off or on by pressing 5 times.

Note: Remove the track screw to adjust the DIP switch

INSTALLATION INSTRUCTIONS

ATTACHMENT

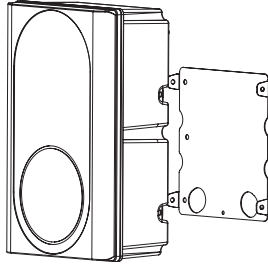

1 x EV Charger & 1 x Fixing bracket *

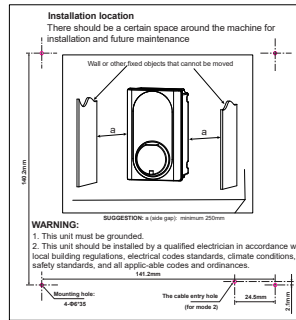

1 x Installation template

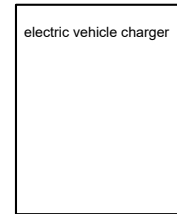

1 x Manual



1 x Elbow wrench



Wiring cap



1 x Sealing rubber

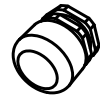

1 x Cable Gland

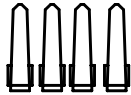

4 x Wall Plugs
M6x30

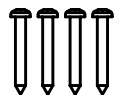

4 x Screw
ST4.2x32

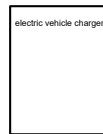

1 x Warranty card

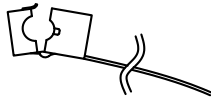

CT**



CT wire terminal**



1 x Sealing rubber

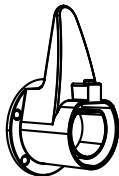

1 x Charger holder***

NOTE: If you are missing any of these parts, contact the customer services 0161 249 6780.

* The bracket is already installed on the charger and needs to be removed for installation.

** This is an optional extra.

*** Just for the charger model with the cable.

INSTALLATION INSTRUCTIONS

TOOLS/MATERIALS REQUIRED (NOT INCLUDED)

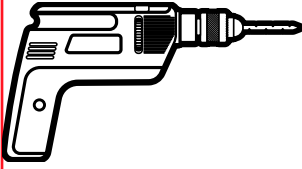

Electric drill

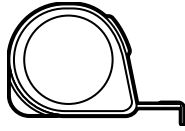

Measuring tape



Safety gloves

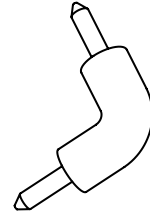

Electric elbow tool

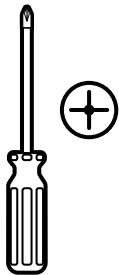

Phillips screwdriver

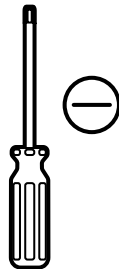

Slotted screwdriver

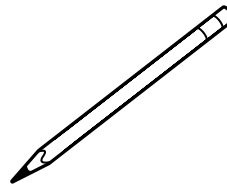

Pencil

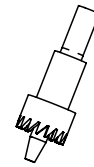

Hole Saws
Mode 1: $\Phi 24\text{mm}$ Bottom hole
(for VEC01 and VEC03)
 $\Phi 28\text{mm}$ Bottom hole
(for VEC02 and VEC04)
Mode 2: $\Phi 18\text{mm}$ (Back hole for
Sealing rubber)



Cable Gland PG21 : $\Phi 28\text{mm}$



Cable Gland PG19 : $\Phi 24\text{mm}$



Sealing rubber : $\Phi 18\text{mm}$

INSTALLATION LOCATION

There should be a certain space around the unit for installation and future maintenance.

SUGGESTION:

a (side gap): minimum 250mm.

*A charging cable holder position needs to be reserved.
(Just for VEC03/VEC04)

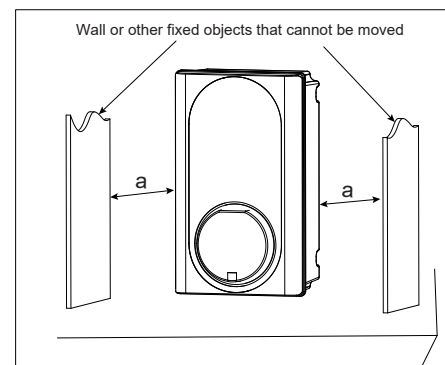

INSTALLATION INSTRUCTIONS

WARNING

- ▲ Make sure that the power source is turned off before installing the unit.
- ▲ Manufacturers and distributors are not responsible for any loss or related responsibilities caused by any incorrect installation.
- ▲ The installer shall not be responsible for the loss and damage of the product, system or property caused by improper installation.

Important:

Before installing the unit, it is necessary to confirm the way of the product's power cable entry. Mode 3 power cable entry is strictly not allowed.

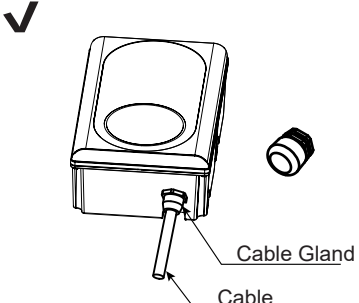
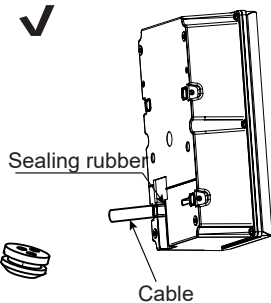
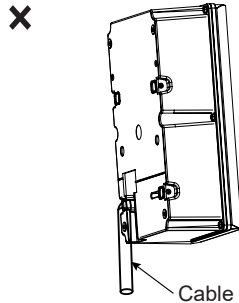
Mode 1	Mode 2	Mode 3
Bottom entry (Best choice)	Back entry	It is strictly forbidden to pass the bottom line through the back.
		

CONNECT ELECTRICAL WIRING

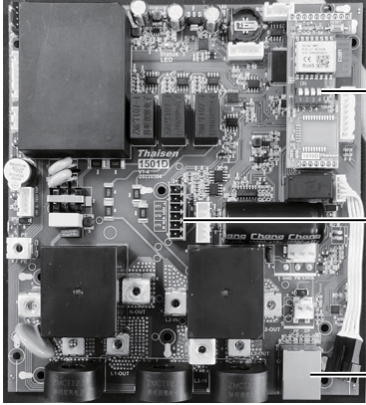

1. DIP switch
2. CT socket
3. Ethernet socket

AC220V~240V 50/60Hz

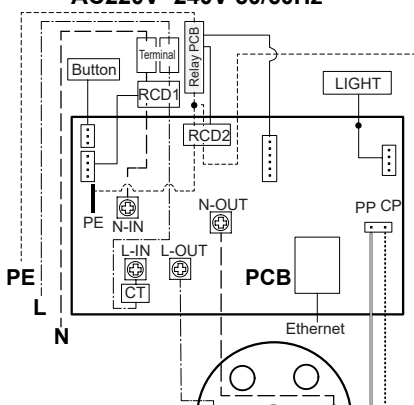

**Socket/
Connector**

CP (Orange) ————
 PP (White) ————
 PE (yellow/green) - - - - -
 N (Blue) - - - - -
 L (Brown) - - - - -

AC380V~450V 50/60Hz

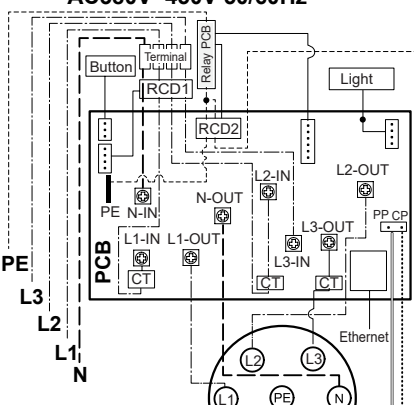

**Socket/
Connector**

CP (Orange) ————
 PP (White) ————
 PE (yellow/green) - - - - -
 N (Blue) - - - - -
 L1/L2/L3 (Brown) - - - - -

Note: The charger must be electrically protected by installing externally a Miniature Circuit Breaker (MCB) and any other protection devices according to the wiring regulations at the time.

INSTALLATION INSTRUCTIONS

INSTALLATION

1. Take the unit and remove the 4 screws on its fixing bracket (The unit is integrated with the fixing bracket and needs to be disassembled first). Keep the screws and fixing bracket for subsequent use;

2. Remove the 6 fixing screws on the front shell and the rear shell, save the screws for subsequent use;

Note: Reference fig.1 for steps 1 and 2.

3. Open the front shell carefully. The front shell is connected to the unit body through a cable. Be careful not to damage or break the cable.

Caution: After opening the front shell, visually inspect the inside. If the wiring terminal block or the fixed component falls off the track, it can be installed back to the track by itself (reference fig. 2)

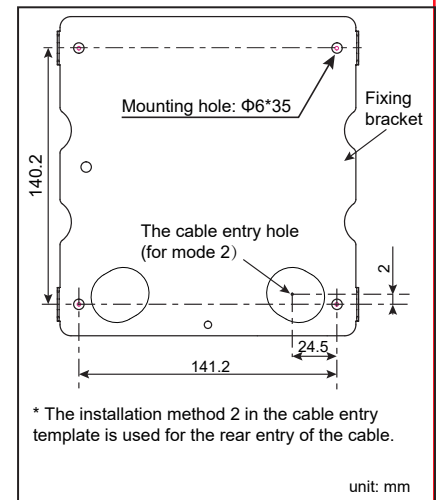
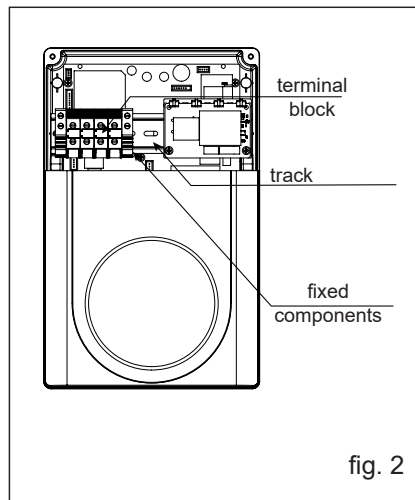
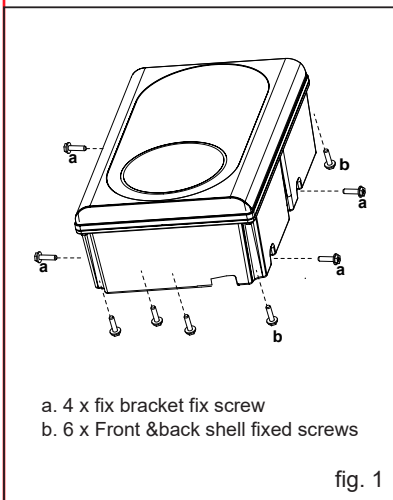

4. **Inlet wire mode 1:** Use the installation template to mark the fixed bracket installation hole position.

Inlet wire mode 2: Use the installation template to mark the position of the fixing bracket installation hole and the cable entry hole.

Note 1: Inlet wire mode 2 which need to pay attention to the correct direction of the installation template.

Note 2: Make sure that the installation template itself is level when the position is marked.

Note 3: Refer to Installation template.

5. Drill holes according to the information prompted by the installation template, and ensure that the hole positions are accurate.

(1). Fixed bracket mounting hole has a diameter of 6mm and a depth of about 35mm.

(2). Inlet wire mode 2, diameter of the cable entry hole needs to be defined according to the actual cable selection, However, it is recommended that the maximum opening diameter should not be bigger than 24mm.

Caution: The edge of the wall opening needs to be repaired, and it must not be a sharp edge to prevent the incoming wire from being damaged.

6. Fixing bracket installation hole inner - insert wall plugs, and use attachment screws(ST4.2*32) fixing fixed bracket to the mounting surface and ensure the screws are fastened well.

Note: If the screws are not fastened well, the fixing bracket may become loose and may interfere with the installation of the housing.

INSTALLATION INSTRUCTIONS

7. According to the size and position below, drill the power cable hole on the shell.

NOTE 1: Inlet wire mode 1, open hole size must be accurate, and the hole diameter is 24mm for VEC01 and VEC03, 28mm for VEC02 and VEC04.

NOTE 2: Inlet wire mode 2, open hole size must be accurate, and the hole diameter is 18mm.

WARNING: Remove burrs around the hole to prevent affecting the seal level.

WARNING: Do not damage internal components, especially internal wiring, when drilling the hole.

8. Clean and remove all the debris that has fallen into the shell due to the punching.

9. Inlet wire.

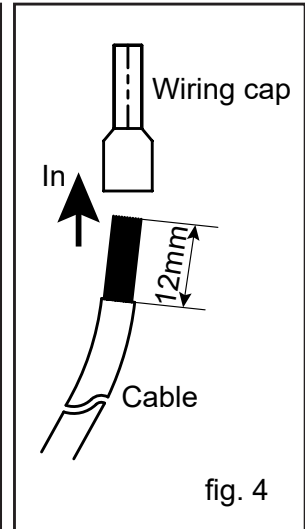
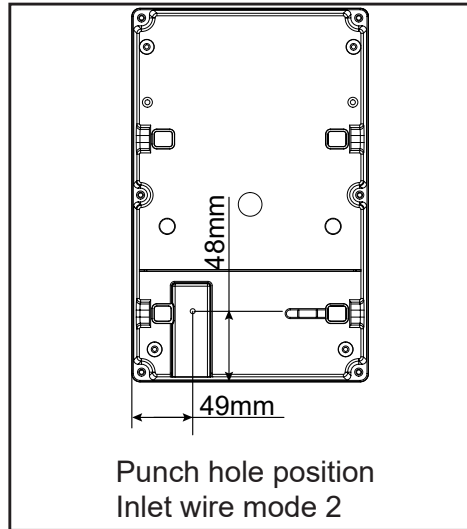
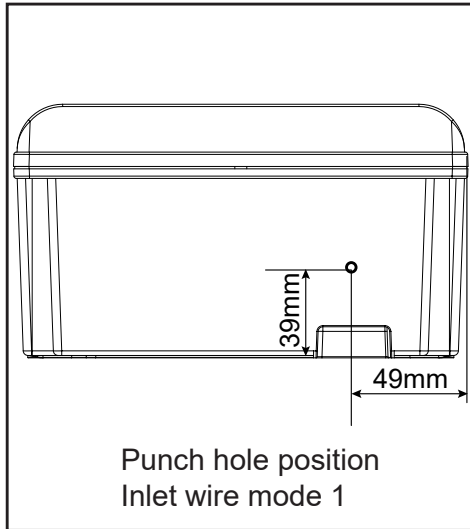

* **NOTE:** Product installation details with OCPP1.6J service agreement. Refer to “Network Connection guide”.

** **NOTE:** Product installation details with power management. Refer to “Power management function installation guide”.

Network Connection guide

1. Drill holes according to fig. 1*.

2. Use the accessory sealing rubber to fix the network cable.

3. One hole of the sealing rubber be cut open with knife, insert the network cable into the sealing rubber, then insert them into the housing, as fig. 8.; Reserve enough length of the network cable to ensure that it can be well connected with the Ethernet interface;

NOTE: During installation, if the network cable line and the plug is separate, you don't have to cut the sealing rubber.

Warning: Seal the opening on the back to achieve the unit's IP rating. Sealing is very important. This involves the safety of the product and must be paid attention.

4. Network cable plug is docked to Ethernet interface.

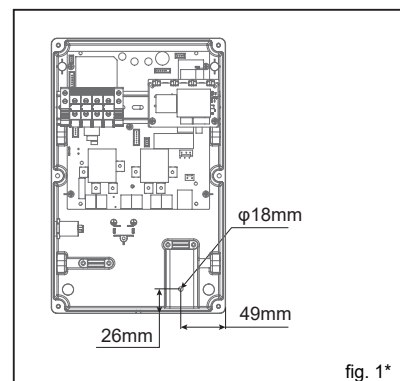
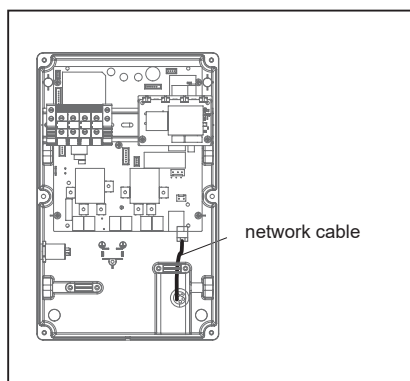

INSTALLATION INSTRUCTIONS

Power management function installation guide

1. Drill holes according to fig. 1**.
2. Use the accessory sealing rubber to fix the CT wire.
3. Insert the sealing part into the housing body, as fig. 8, thread the CT wire into the sealing part, one hole corresponds to one CT wire (if the product is single-phase, just need to use a sealed wire hole, and the other two do not need to be pierced broken), after the CT cable is inserted, reserve enough length to connect to the CT interface;
4. Crimp the CT wire to the CT wire terminal and then insert it into the CT interface, as following fig. 2**
5. Open the CT and fixed it to the main incoming line (one CT is only allowed to pass through one line, and three CT for three-phase power are allowed to pass through three lines).

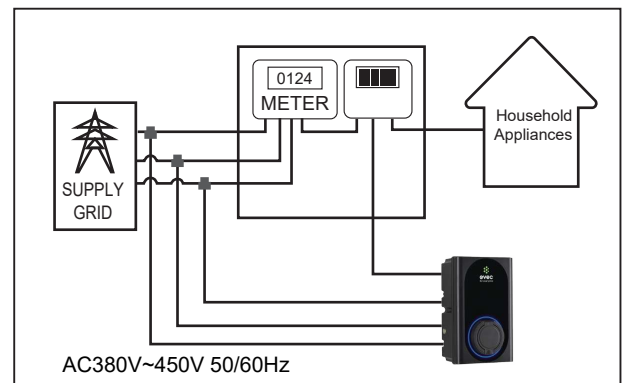
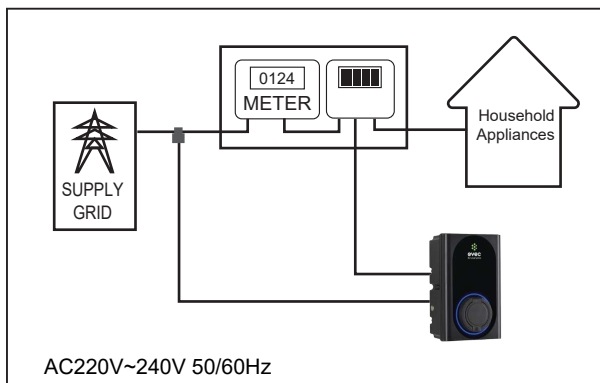
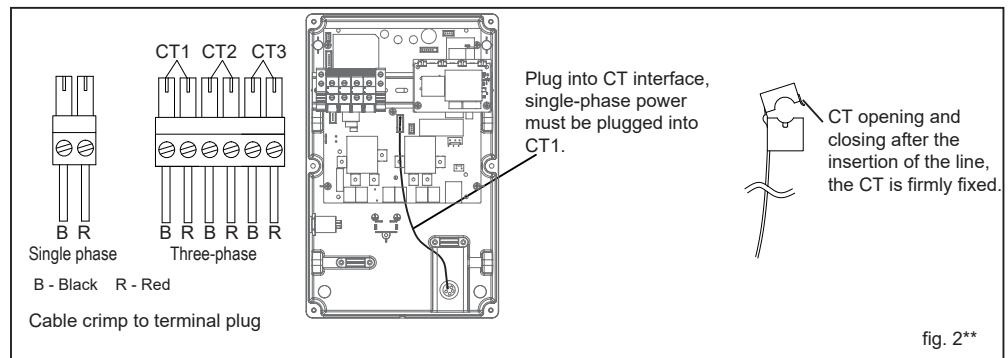
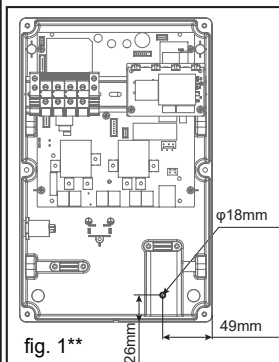

NOTE:

If there is a need to extend the CT cable, **twisted-pair cable like CAT5 must be used**. DO NOT use mains cable, bell wire or speaker cable.

It is important to use only twisted-pair cable to maintain signal integrity. Up to four CT cables can be extended using the separate twisted pairs in a CAT5 Ethernet cable. The cable can be extended up to 40m.

• **Remember to a separated twisted pair for each CT.**

• When joining CT wires make sure that the ends of the wires are twisted tightly together and joined using crimps, screw terminals or solder.

• Avoid using lever clamp type terminals as these do not provide a reliable connection at very low currents.

INSTALLATION INSTRUCTIONS

MODE 1

a1. Check the cable gland parts as shown in fig. 5.

a2. Pass the gasket and the main body through the opening hole of the shell and lock it with a nut, as shown in Fig. 6.

a3. Insert the pressing head into the cable, and then thread the cable into the main body that cannot be pulled off, as shown in Fig. 7.

a4. Trim and cut the cable to the proper length, lock the pressing head to secure the cable.

a5. Refer to this article connect electrical wiring to connect the cable to the terminal block.

NOTE: connecting wiring reference fig. 4

WARNING: To ensure the rated IP protection level of the product, must use the cable gland in the accessories.

a6. Confirm and remove the debris inside the housing caused by punching and wiring.

a7. Ensure that all cables are connected correctly and securely, and are not loose or damaged.

a8. Screws lock the front and rear shells tightly.

Caution: Need to use the screws removed from the original position.

Before installing the front shell, it must be ensured that the sealing strip in the front shell groove has not fallen off and is in the right position. Ensure that all seals performed on the unit can reach the IP rating.

a9. Screw the unit to the fixed bracket.

Caution: Use the screws removed from the original position.

Note: a8, a9 refer to fig. 1, reverse operation.

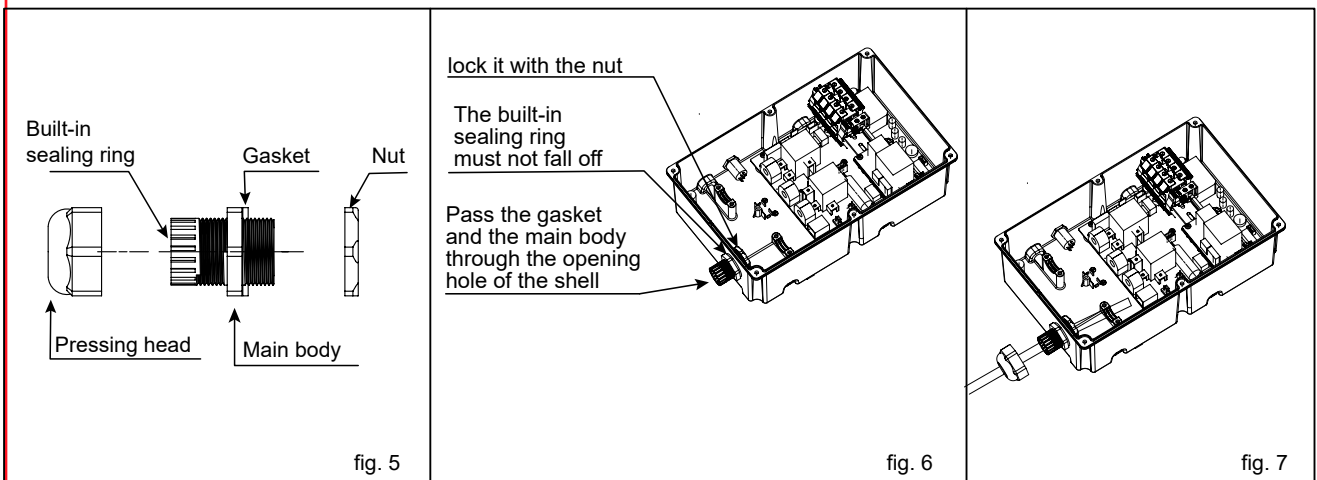

INSTALLATION INSTRUCTIONS

MODE 2

b1. Insert the sealing rubber into the housing, as shown in Fig 8, insert the bare wire into the sealing rubber, one hole corresponds to one bare wire, after all the wires are inserted, leave enough length of the cable to connect to the terminal block.

NOTE1: To ensure the rated IP protection level of the product, must use the sealing rubber in the accessories.

NOTE2: Poke the middle position of the sealing rubber before installing this item.

b2. Screw fastening the entire rear shell to the fixing bracket.

Caution: Use the screws removed from the original position.

b3. Refer to this article connect electrical wiring to connect the cables to the terminal block.

NOTE: connecting wiring refer to fig. 4

b4. Seal the opening on the back to achieve the unit's IP rating.

Warning: sealing is very important. This involves the safety of the product and must be paid attention.

b5. Screws lock the front and rear shells tightly.

Caution: Use the screws removed from the original position.

Before installing the front shell, it must be ensured that the sealing strip in the front shell groove has not fallen off and is in the right position.

Make sure that all seals performed on the unit can reach the IP rating.

Note: if there is no suitable electric tool, the elbow wrench provided in the accessories can be used to tighten the screws of the front and rear shells.

IMPORTANT NOTE: It is the responsibility of the installing engineer to satisfy themselves, that all cable terminations throughout this product are secure and tight and have not become loose, strained, or disconnected during transit and/or installation.

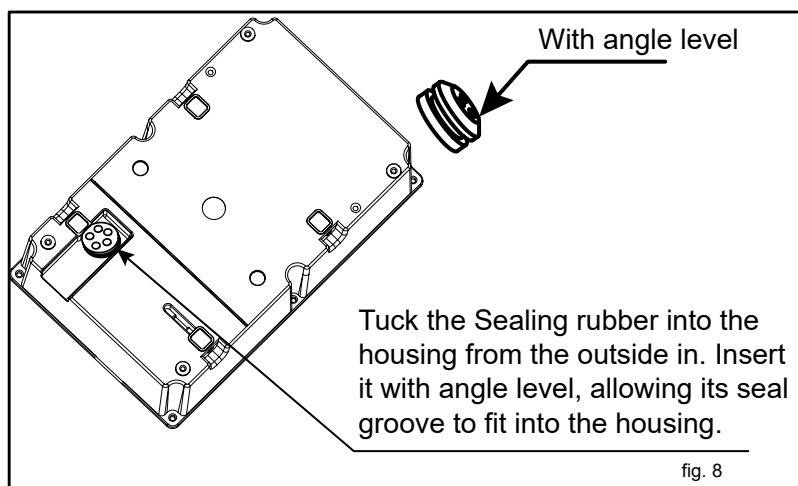

After the front and rear shells are installed, check whether there is a loose gap between the front and rear shells. Make sure that there is no loose gap.

INSTALLATION INSTRUCTIONS

Installation of the cable holder

1. Take out the charger holder.
2. Find a suitable location near the EV charger box, which must be more than 0.5m above the bottom surface and not higher than 1.5m.
3. Align the charger holder in position and mark the four mounting holes.
4. Drill the 4 holes as the marks at dia 6mm, 35mm deep.
5. Insert the wall expansion plug.
6. Screw the charger holder to the wall.
7. Installation is complete.

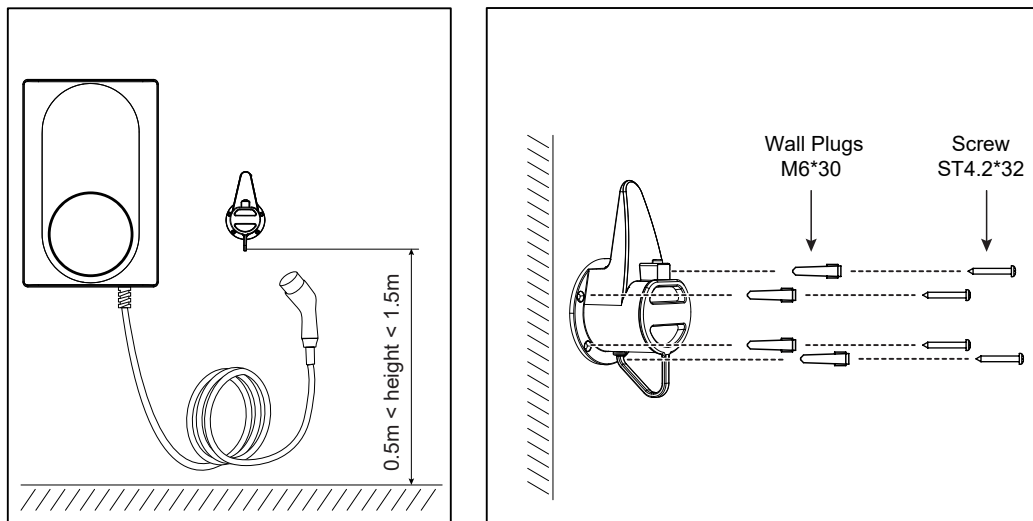

THE INSTRUCTION OF THE CABLE CHARGER HOLDER

1. There is a clicking sound when the tip is inserted.
2. When pulling out the charger, you must first press the lock button and pull out the charger at the same time.

INSTALLATION INSTRUCTIONS

SET THE DIP SWITCH

You need to set the corresponding position of the current DIP switch according to the min. wire size shown in the chart and the rated current of the Circuit breaker (factory setting 32A). refer to the steps below.





Caution 1: The following operations must be powered off.

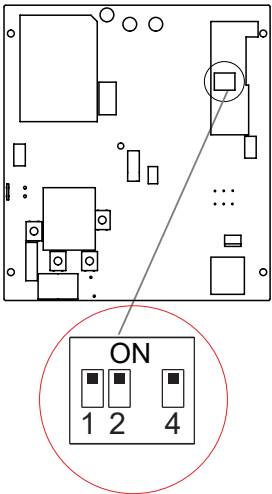

Caution 2: Incorrect setting DIP may cause hazards such as overheating or fire of the incoming wire.

1. Locate the position of the two-position DIP switch on the power supply board, like picture.
2. Setting the switch to the desired position:

WARNING: Electrical Power Switches must only be set by a qualified electrical installer. Incorrect setting may lead to equipment damage and / or personal injury. The current rating must not exceed the supply rating.



DIP switch position				
Current(A)	32	16	13	10
Min. wire size (copper)	6mm ² or 10AWG	2.5mm ² or 13AWG	2mm ² or 14AWG	1.5mm ² or 15AWG
Circuit breaker (Amps)	40	20	20	16

DIP switch position		
CONTROL	APP and OCPP	Only OCPP

NOTE:

1. when you set the DIP4 switch position to on, both APP and OCPP can control the charger;
2. when you set the DIP4 switch position to off, only OCPP can control the charger, and the function button can adjust the randomised delay off or on by pressing 5.

NOTE: Remove the track screw to adjust the DIP switch.

INSPECTION

1. Check that this unit must be grounded (Earthed).

Make sure you are satisfied that the installation is complete and is in a safe condition.

3. Switch ON the power, which it will cycle the red, blue and green lights to self-check and then enter the corresponding light indication. The unit and test in accordance with the current Electrical Wiring Regulations.

NOTE: Make sure this product has been installed in compliance with the current Electrical Wiring Regulations.

Product exploded view

Product exploded view and spare part list.

1.VEC01 and VEC02

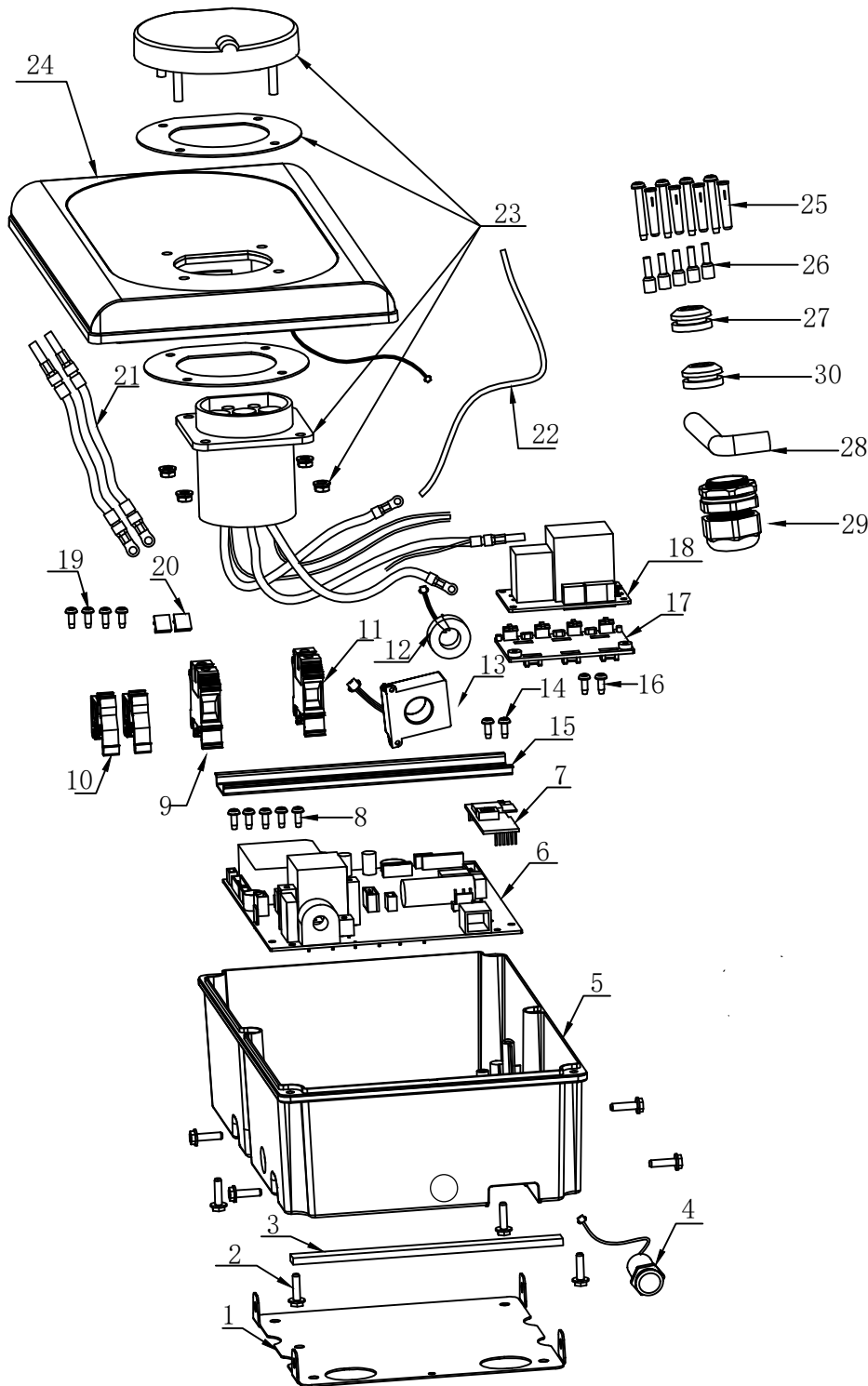

序号	部件名称
1	Fixing bracket
2	Screw
3	Waterproof strip
4	Function button
5	Bcak shell
6	PCB
7	APP-WIFI module
8	Screw
9	terminal block N
10	fixed components
11	terminal block L
12	RCD2
13	RCD1
14	screw
15	Trcak
16	screw
17	plastic fixing plate
18	Relay PCB
19	Screw
20	identification
21	Internal wiring
22	seal
23	Socket
24	Front shell
25	Wall Plugs / screws
26	Wiring cap
27	sealing rubber
28	Elbow wrench
29	Cable gland
30	sealing rubber

Product exploded view

Product exploded view and spare part list.

1.VEC03 and VEC04

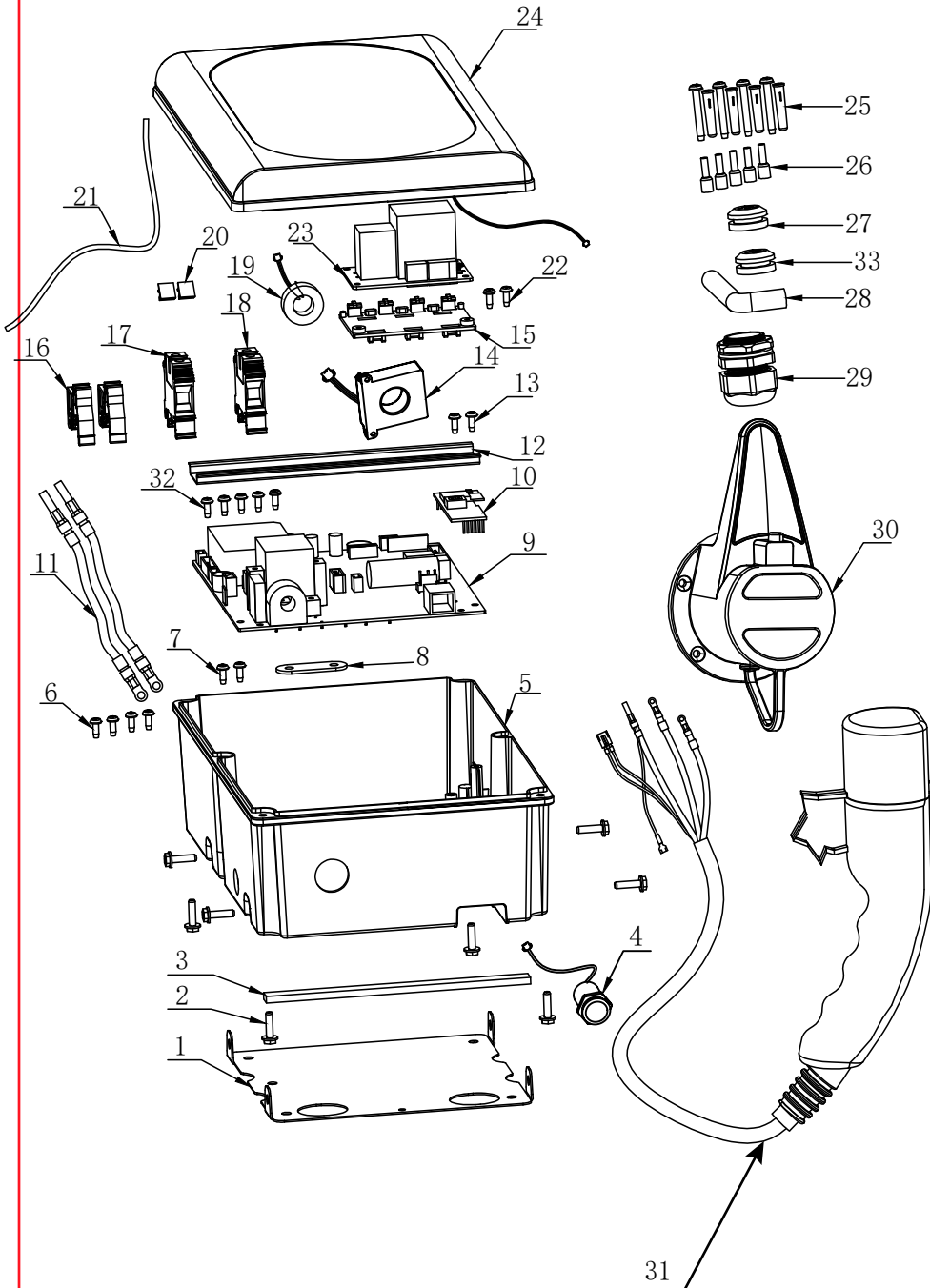

序号	部件名称
1	Fixing bracket
2	Screw
3	Waterproof strip
4	Function button
5	Back shell
6	Screw
7	Screw
8	Iron sheets
9	PCB
10	APP-WIFI module
11	Internal wiring
12	Track
13	Screw
14	RCD1
15	plastic fixing plate
16	fixed components
17	terminal block N
18	terminal block L
19	RCD2
20	identification
21	seal
22	Screw
23	Relay PCB
24	Front shell
25	Wall Plugs / screws
26	Wiring cap
27	sealing rubber
28	Elbow wrench
29	Cable gland
30	Cable holder
31	Cable and connector
32	Screw
33	sealing rubber

APP INSTRUCTION

REGISTER

Step 1. Application platform download EVEC APP.

You can download it through the QR code on the front cover page of this manual , or google store or APP store.

Step 2. Open the EVEC APP, register an account to log in.

Note: You can register your account through your mobile phone number or email. The following takes mobile phone number registration as an example to describe the steps in detail:



Step 2-1: Click Sign up

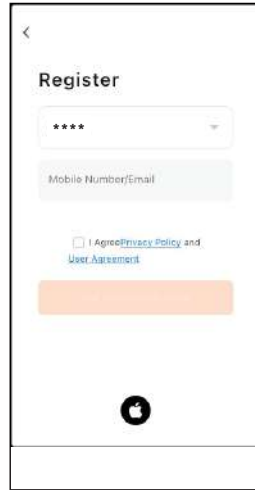

Step 2-2: Check the app agreement, enter the registered mobile phone number and click to get the verification code

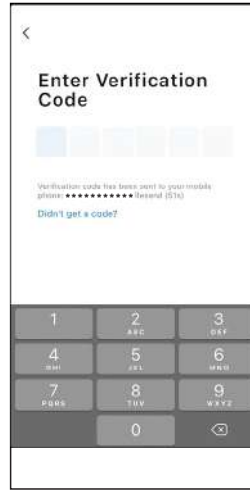

Step 2-3: Input verification code.

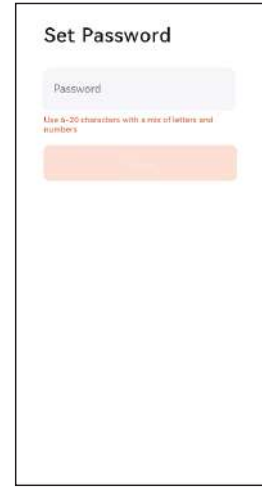

Step 2-4: Input the account login password and click done to complete the registration.

ADD DEVICE

Step 3. Click log in on the App, input the newly registered account and password to log in to the EVEC APP.

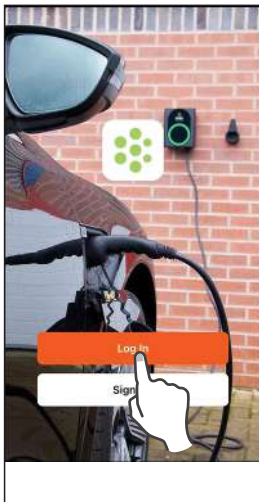

Step 3-1: Click log in

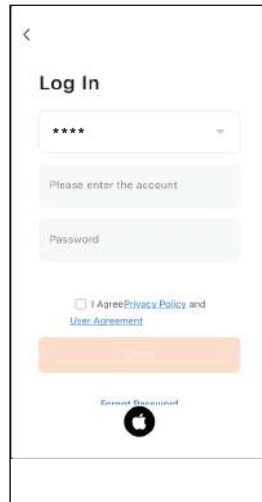

Step 3-2: Check the app agreement, enter the registered account and password, and click log in.



Step 4: Add device.



Step 5: Network and bluetooth not turned on.

Step 4. Press the function button on the charger for 10s(beep 2 times) to reset the wifi(refer to the function button instruction for the wifi reset operation guide),Click “Add Device” to add the charger device that needs to be connected.

Note: Make sure the charging lead is not plugged into a car before adding the device.

Step 5. After turning on wifi , bluetooth and geolocation,the EVEC APP automatically searches for the charger.

Note: 1.When connecting the charger,the mobile phone must be **close** vicinity to the charger.

APP INSTRUCTION

2. The charger needs to be connected to WiFi. If the WiFi signal is weak or absent, the charger will not receive the signal or delay the connection. Therefore it is recommended to add an enhancement device for WiFi receiving signal near the charger. Note: To check if your WiFi can reach the charger and have a good signal check your smart device or smart phone whilst standing close to the charger with the WiFi tuned on if the signal can be seen above 2 bars then it is ok if not a WiFi booster or repeater needs to be added. Note: The ethernet port is not for the smart App it is only for OCPP use.

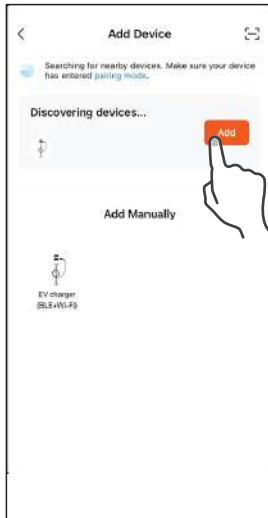

Step 6-1: Click Add.



Step 6-2: Enter wifi name and password, then click the next



Step 6-3: Loading

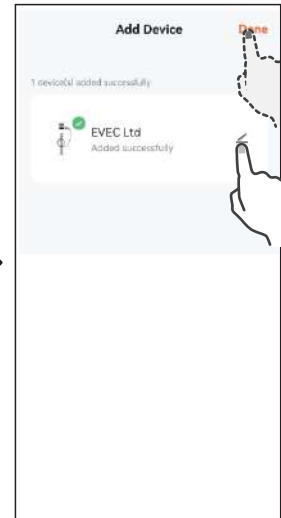

Step 7

Step 6. After clicking ADD, enter the wifi and wifi password, wait for the device to connect to the network.

Step 7. If you need add a new device name, click “✎” if not, click “done” to confirm the connection is successful.



Step 8: Default selection interface



Step 10: Device control interface

Step 8. The first connection will appear with the default screen, you can select the default mode, edit the charging time or select the manual mode.

Step 9. Click manual mode.

Step 10. Connecting to the car, after click Enable to start charging, then the charger will charging after randomised delay.

APP INSTRUCTION

OPERATE INTRODUCTION

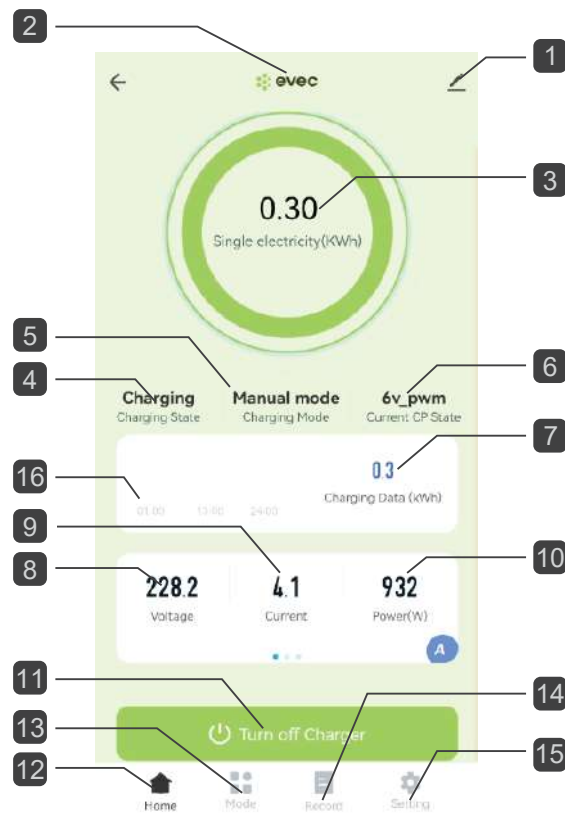

INTERFACE INTRODUCTION

- | | |
|------------------------------------------|------------------------------|
| 1 Edit | 8 Charging voltage |
| 2 Device name | 9 Charging current |
| 3 Single charging energy consumption | 10 Charging power |
| 4 Charging state | 11 On/off |
| 5 Charging mode | 12 HOME |
| 6 CP state | 13 Mode |
| 7 Cumulative charging energy consumption | 14 Record |
| | 15 Setting |
| | 16 Energy consumption record |

APP INSTRUCTION

1 Edit

(1). you can set the charger name and icon by “✎”

(2). Offline Notification: When the device is powered off, it will prompt the device to be offline on the home interface.

(3). Share Device: You can share it with others use according to the software, email, and EVEC account bound to the app. Be shared others only have using right, and doesn't have right to share it again.

NOTE: When using EVEC account to share, the shared account can be added the device without any operation. Refer to the following steps:

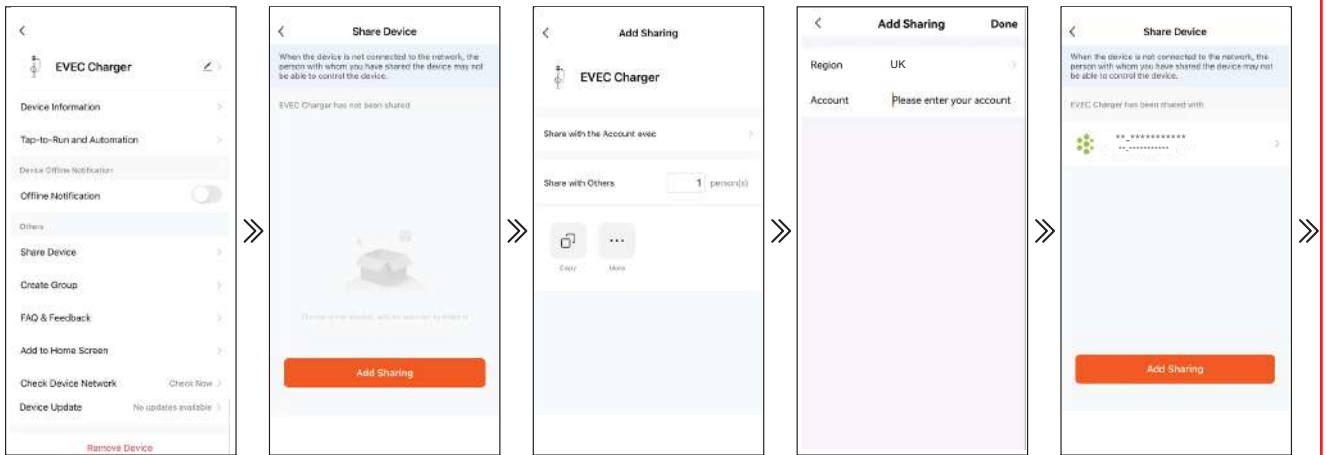

step1: click“Share Device”.

Step2: click“Add Sharing”.

Step3: click“share with the account EVEC”.

Step4: Input EVEC account at account.

Step5: Done.

(8). Device Update: When the device update, open EVEC to receive an update prompt, and manually confirm the update. When you ignore it, you can find the update settings at this location again

(9). Romve Device

1. Disconnect: Disconnect device connection.

2. Disconnect and wipe data: Disconnect device connection and wipe “Charging record” and “Error Log”data .



APP INSTRUCTION

13 Charging mode

(1).manual mode:control charger by Enable and Turn off charger on APP.

(2).Schedule: Timed charging.

NOTE 1: When you choose the set time point to turn on the charging , you must adjust the hours setting, otherwise the default charging time is only 1 minute;

2: When you choose the set time point to turn off the charging, there is no hours setting;

3: When you choose the date choose, this time of each week will default to on or off charging.

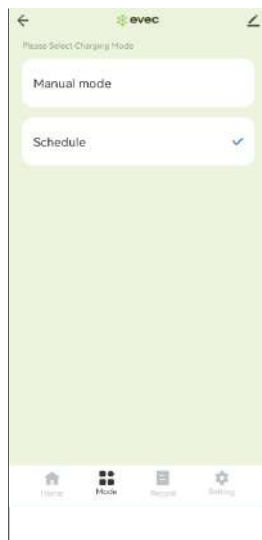

Charging mode

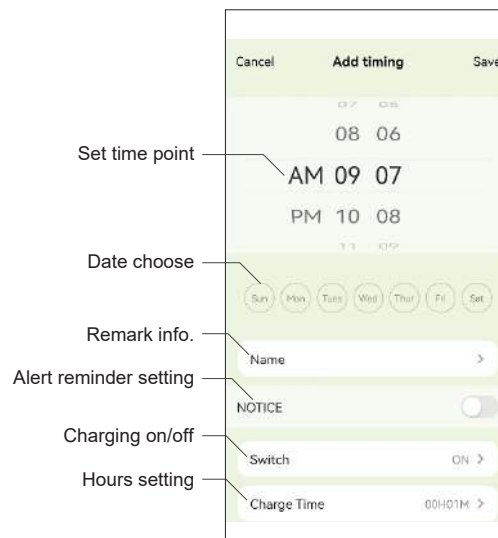

Charging mode

14 Record

You can view “Charging record” and “Power” on this interface.

NOTE:Only the information that is turned on or off through the APP will be recorded in the charging record.

When the charging is turned on by the function button, there is no charging record.

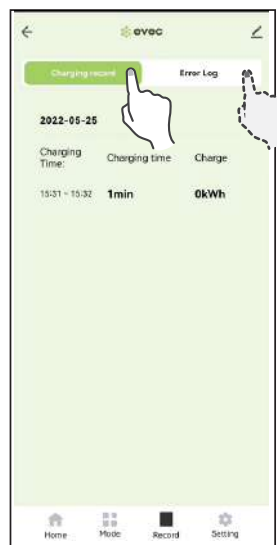

Record

APP INSTRUCTION

15 Setting

(1). Order input: Input order tab.

you can set power management from this tab. To use this function a CT clamp is required. To set maximum current:

1. Click Input order tab to enter command input field.
2. Input "home value", this value is the limited protection value of household entry current, the setting range is 08-120, and the factory default setting is 45A (the system will automatically optimize the current value when the actual value is 5A less than the value set); the setting value is recommended to be set according to the rated current value of the total household current.

(2). Set Current tab(A): You can set max charging current, max charging current not more than the current of DIP switch setting.

NOTE: 1. After the APP is connected at the first time, the current value displayed here is not the set current value, it is a current setting form.

2. It will take effect only after clicking to enter to set any current value, and the current value adjustment range is 6-32A;

3. If the current value has never been set here, the value displayed here is invalid

(3). Temperature Monitor: can check device interior temperature value.



Input order	Function
HOME value	Set household entry current
RESET	Clear all charging data

NOTE: If the order is inputted incorrectly, the device will still beep twice, but the order will not be executed; The wrong order that was inputted cannot be corrected, until you disconnect device from the APP and wipe the data and connect it again.

(4).IP Address: Change the address of the OCPP back-office server;

(5).ID: The product name in the OCPP back-office server.

NOTE:1.make sure the ID is only.

2. After the ID is replaced, it can be concluded that the ID replacement is complete only when the Device number is consistent with the replaced ID; If the Device number does not change after changing the ID, you can exit the APP and then power off and restart the EV charger.

3.After the IP or ID is replaced, it must be powered off and restarted to take effect.

FAULT INTERFACE

If device has fault, you can view the cause of the failure in the center of the main interface of the APP.



TROUBLESHOOTING

INDICATOR LIGHT AND MAINTENANCE

NOTE: All product parts appearing below can be found in Exploded view and spare part list

Serial unंबर	Light Display Status	Product Status	Instructions
1	Blue, green and red flashing alternately	Product power-on self-check	<p>Each time the product is powered on, after three self-checking, the blue light glowing (not connected to the car) or the blue light flashing (connected to the car) judged to be normal; If there is a red light failure after three self-checking, you can repair it according to the maintenance instructions of the corresponding state (6-15); If there is a continuous self-checking, it is determined that the product is faulty, and the maintenance is as follows: 1). After the product is powered off, check whether the connection between RCD1 and the PCB is damaged or open circuit, and whether the connector at both ends are well inserted into the PCB and RCD1; 2). Check whether the connecting wire between Relay PCB and PCB is damaged or open circuit, and whether the terminal of Relay PCB is well inserted into the PCB; 3). Check whether the connecting wire between RCD2 and Relay PCB is damaged or open circuit, and whether the of RCD2 is well inserted into the Relay PCB; After all the above tests are completed, the fault can be recovered after the product is powered on again (if there are defective parts, it needs to be replaced). NOTE: If the product cannot be restored to normal, replace RCD1、RCD2、relay PCB successively, and finally replace the PCB.</p> 

TROUBLESHOOTING

Serial unumber	Light Display Status	Product Status	Maintenance
2	Blue light glowing	Standby	<p>Standby state indication, not connected to the vehicle, it is judged to be normal;</p> <p>If the blue light is still on after connecting to the car, it is determined that the product is faulty, and the maintenance is as follows:</p> <ol style="list-style-type: none"> 1. After the product is powered off, check whether the connection between PE and PCB is damaged or open circuit, and whether the connector of PE is well inserted into the PCB; 2. Check whether the CP/PP cable is damaged, whether the position of the CP cable and the PP cable is correct, and whether the CP/PP connector is well inserted into the PCB; <p>After all the above tests are completed, the fault can be recovered after the product is powered on again.</p>  <p>connector of PE</p> <p>PP Cable (grey)</p> <p>CP cable (black)</p> <p>connector of CP/PP</p>

TROUBLESHOOTING

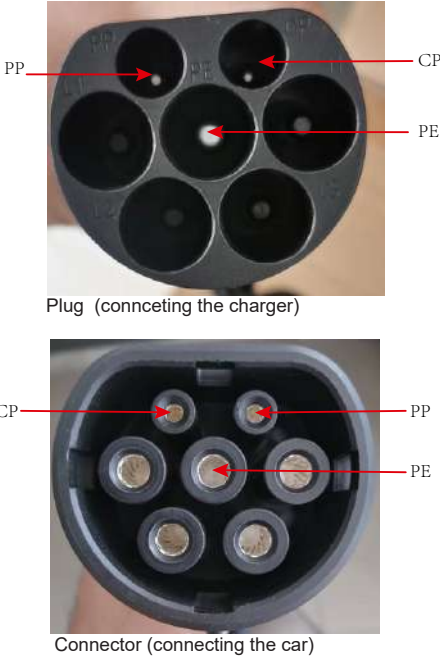
Serial unnumber	Light Display Status	Product Status	Maintenance
3	Blue light flashing	Connection confirmation	<p>The connection with the vehicle indicates that it is not charging, and it is judged to be normal; Connect to the vehicle to start charging, after beep once, charge the vehicle within 10 minute, and the indicator light turns green and lights up to determine that it is normal; After starting the charging for more than 10 minute, after beep once, the blue light is still flashing and the car is not charged. The reasons for the problem are as follows: 1. Many models of vehicles are equipped with an on-board charging switch, and the vehicle can be charged only after the vehicle is allowed; Solution: Turn on the car charging switch; 2. For many types of vehicles, charging of the vehicle is prohibited when the door is not closed or not closed tightly; Solution: close the vehicle doors; 3. The product is in manual mode or schedule mode under the control of OCPP+APP; Solution: 1) Connect the APP, and click enable to start charging on the first page of the APP; 2) In the standby state (the blue light is always on), press the function button five times and then switch to the plug-and-charge mode to charge the vehicle; 4. The product is set to only allow OCPP to be independently controlled, and is not charged within the allowable charging time set by OCPP; Solution: 1) After connecting with the vehicle, automatically charge the vehicle while waiting to enter the allowable charging time set by OCPP; 2) Adjust the No. 4 DIP switch to ON, set it to OCPP+APP control, refer to Reason 3. 5. The plug or connector of cable is damaged; Solution: After the product is powered off, measure whether the PP and PE resistances of the tip of the charging plug are normal (32A) Plug cable resistance $220\Omega \pm 3\%$; 16A plug cable resistance $680\Omega \pm 3\%$, just replace the plug cable abnormally;</p> <div style="text-align: center;">  <p>Plug (connecting the charger)</p> <p>Connector (connecting the car)</p> </div>
4	Green light glowing	Charging	<p>1. The green light glowing and charging is Correct normal. 2. The green light glowing and not charging, check whether the output voltage of the EV charger is normal, if there is no voltage It is necessary to replace the PCB, and there is a voltage to check whether the charger plug cable is in good condition.</p>
5	Green light flashing	Disconnect charging from APP	normal

TROUBLESHOOTING

Serial unnumber	Light Display Status	Product Status	Maintenance
6	Red light glowing	Over temperature protection	<p>The cause is generally too high ambient temperature (such as the product is exposed to the sun) and long-term high-current charging makes the internal temperature of the product too high.</p> <p>analyse as below:</p> <ol style="list-style-type: none"> 1. If the red light is still on at a current of more than 8A, the power supply of the product should be disconnected immediately. <p>Solution: Determine the PCB failure and need to replace the PCB;</p> <ol style="list-style-type: none"> 2. If the red light is always on and the current is charged below 8A, the internal temperature of the product is between 70-85°. <p>Solution:</p> <ol style="list-style-type: none"> 1) The vehicle can continue to be charged at the current speed of 8A; 2) Disconnect the charging, cool down naturally or artificially cool down to below 60°, restart the power supply of the charging to the car; 3. If the red light turns on and turns to a current below 8A after charging for a period of time, the charging is disconnected (the tram is not fully charged), it is determined that the internal temperature of the product has been over 85°. <p>Solution: Disconnect the charging, cool down naturally or artificially cool down to below 60°, restart the power supply of the product to charge the car;</p> <p>Remarks: 1. The internal temperature of the product can be viewed through the temperature on the setting page on the APP.</p> 
7	Red light flashing One fast, one slow	Emergency stop	Emergency stop status indication, pull the plug to return to normal.

TROUBLESHOOTING

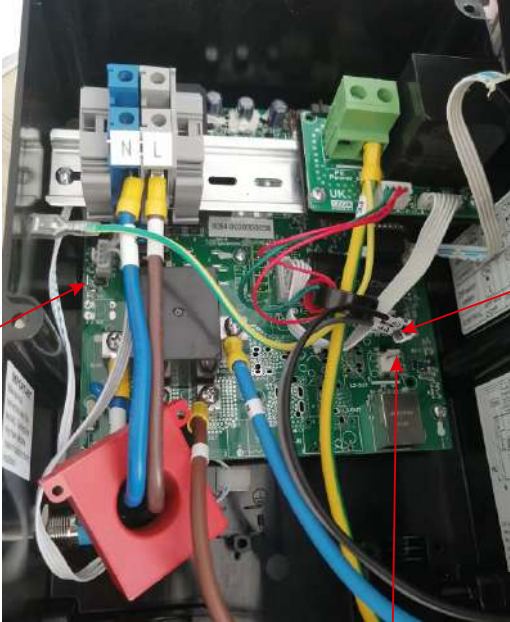
Serial unumber	Light Display Status	Product Status	Maintenance
8	Red light flashing One fast, two slow	CP fault	<p>CP failure status indication, maintenance plan:</p> <ol style="list-style-type: none"> When not connected to the car, disconnect the power supply of the product: <ol style="list-style-type: none"> VEC01 and VEC02 products: <ol style="list-style-type: none"> The fault is reported after inserting the plug and connector, and the cable can be replaced directly; If the plug and connector is not inserted, unplug the CP/PP connector, and measure whether the CP connector is short-circuited with the PE wire. If it is short-circuited, check the short-circuit position. Repair or replace the socket of the charger; If the plug and connector is not inserted, unplug the CP/PP connector and the ground terminal of the PCB, and measure whether the CP pin on the PCB and the PE are short-circuited. It needs to replace the PCB; VEC03 and VEC04 products: <ol style="list-style-type: none"> Unplug the CP/PP connector, and measure whether the CP connector is short-circuited with the PE wire. If it is short-circuited, check the short-circuit position and repair or replaceconnector of the charger. Unplug the CP/PP connector and the ground terminal of the PCB, and measure whether the CP pin on the PCB and the PE are short-circuited. It needs to replace the PCB. After connecting with the vehicle, this fault is reported: <ol style="list-style-type: none"> Pull out the connector of charger from vehicle, if it can return to normal, check the vehicle; Some cars can be charged normally, and some cars will have this fault when charging. It is determined that the CP voltage tolerance of the car is too large, which exceeds the recognition of the charger. In this case, you can directly contact the dealer to upgrade the software separately for this product, and enlarge the CP voltage tolerance of the product identification. After providing the virtual ID to the dealer, you can wait for the upgrade. Note: (1). Virtual ID search method and path: After connecting APP, go to "APP home page - (top right corner) - device information - virtual ID" (For the path, please refer to the introduction of the APP); (2). The software upgrade must be clicked through the APP to agree before upgrade; (3). At present, the CP voltage approval range of our EV charger is in line with the European standard. (4). The PE and CP positions of the Plug and connector can refer to the pictures in the blue light flashing maintenance instructions. <div data-bbox="858 1234 1489 1937" style="text-align: center;">  <p>CP (the corresponding text is below)</p> </div>

TROUBLESHOOTING

Serial unumber	Light Display Status	Product Status	Maintenance
			
9	Red light flashing Two fast, two slow	Leakagecurr fault	The RCD1 test shows that the leakage current exceeds AC30mA or DC6mA, the solution: 1) The line connecting the product and the vehicle has leakage and repair.
10	Red light flashing Three fast, one slow		RCD2 test shows that the leakage current of PE line exceeds AC30mA, the solution: 1)The reason is that multiple devices share a set of grounding, and the leakage current of other devices is conducted to the PE line of the product. After the product is powered off, determine the PE line, restart the product after repair
11	Red light flashing Two fast, one slow	Over current	<p>When the product is charging the car, the actual charging current value exceeds the rated current value, and the over current fault is determined. The solution:</p> <p>1) The cause of the fault mostly occurs when the over current signal is accidentally touched when the product interacts with the vehicle information, and the vehicle can be charged normally after the connector is drawn and recovered;</p> <p>2) When 1) cannot be solved, it is necessary to detect whether there is a fault in the vehicle;</p> <p>Note: The charger is to give feedback to the vehicle according to the signal sent by the vehicle volume.</p> <p>When the product exceeds the rated current, the charger will make an over current fault to protect the vehicle and the product itself.</p>
12	Red light flashing Three fast, two slow	Under voltage fault	The power supply voltage of the product is lower than approximately 203V. When the power supply voltage of the product returns to above 208V, it can automatically return to normal.
13	Red light flashing Four fast, one slow	Over voltage fault	The power supply voltage of the product is higher than approximately 260V. When the power supply voltage of the product returns to below approximately 252V, it can automatically return to normal
14	Red light flashing Six fast, two slow	Adhesion fault	PCB relay components can not act correctly when the power is disconnected, the solution: 1) After the product is powered off, restart it to return to normal. 2) After 1 or multiple attempts are invalid, replace the PCB.
15	Red light flashing Seven fast, one slow	Earth fault	<p>There is an open circuit between the PE line connected to the product and the circuit breaker or there is a voltage higher than 70V between the PE line and the N line, the solution:</p> <ol style="list-style-type: none"> 1. After the product is powered off, check whether the N line and the L line are reversely connected, and restart after the correct connection; 2. After the product is powered off, check whether the circuit breaker and the PE wiring of the product have an open circuit position, and restart after maintenance; 3. After the product is powered off, check whether the circuit breaker and the PE wire terminal are in poor contact, and then restart after re-crimping firmly; 4. After the product is powered off, restart it directly. During the product self-check (red, blue, and green lights flashing), listen to whether there are 2 times of relay pull-in and disconnection sounds, if there is no that needs to be replaced with PEN module;

Q&A

1. The new installed EV charger can charge the car, but no matter how it is adjusted, the maximum charging current can only reach 13A or 6A;

solution:

1) Connect to APP, check the software version number in the APP “homepage-setting (lower right corner)-software version”, the version number has three digits, when the second digit is 1, it corresponds to the VEC01 and VEC02, and 2 corresponds to the VEC03 and VEC04. Check whether it is correct. If it is not correct, you can contact the distributor to upgrade the equipment separately;

For example: Software session V1.1.1



2) For this problem with the EV charger that has been used for a period of time, check whether the charging plug is damaged and the internal resistance of the charging plug whether it is damaged, the car end or the charger end cannot detect the correct signal of the plug, and can only be charged according to 6A or 13A, replace the charger cable.

3) Some model cars require that the doors must be closed when charging. If the doors are not closed, it will be charged according to the minimum current.

2. The device cannot be found when the APP is connected

solution:

1) Re-search after turning on the mobile phone's Bluetooth, WIFI and geolocation;

2) Check the WIFI signal status of the mobile phone, if the mobile phone signal is less than 2 bars, you need to add a wifi amplifier near the product;

3) Press and hold the function button for 10 seconds when the blue light glowing, and re-search for the device again after hearing two beeps;

3. Turn on or off the charging through the APP, no response;

solution

1) Check whether the product is offline (power failure, network loss or network disconnection,

Weak) it is recommended to add a WIFI amplifier; if the product is disconnected, it can be powered on again;

2) Check the connection between the charger and vehicle is OK or not.

4. When a three-phase electrical product is connected to a single-phase electrical power supply, the live wire must be connected to L1, otherwise it cannot work.